



SYSTEM_PRO

Canister Vac

Household Type

Owner's Guide

Model S3680 Series



IMPORTANT

Do not return this product to the store. Call 1-800-800-8975* Monday - Friday, 8 am to 7:30 pm CST and 10 am to 6:30 pm Saturday or visit our web site, www.sanitairevac.com for any of the following:

- assembly problems
- replacement of broken or missing items
- to order replacement parts and accessories
- to locate the nearest Sanitaire Warranty Station

*En Mexico llame al (55) 5343-4384

www.sanitairevac.com

PLEASE RETAIN

We suggest you record the model, type and serial numbers below. They are located on the silver rating plate on your cleaner. For prompt and complete service information, always refer to these numbers when inquiring about service.

Model & Type _____

Serial No. _____

It is also important to keep your receipt as proof of date of purchase.

Index

Important Safeguards	2
Service Information	2
Use	3
Accessories.....	3-4
Maintaining.....	4
Dust Bag	4-5
HEPA Filter.....	5
Problem Solving.....	6
Warranty.....	7

GENERAL INFORMATION

To reduce the risk of electric shock, this appliance has a polarized plug (one blade is wider than the other). The plug will fit in a polarized outlet only one way. If the plug does not fit fully in the outlet, reverse the plug. If it still does not fit, contact a qualified electrician to install the proper outlet. Do not change the plug in any way.

The bag may have come dislodged in shipping. Check the bag to insure proper seating before attempting to use the cleaner. Do not operate the cleaner without a dust bag or the filters. Damage may result to the motor (see Dust Bag and Filter).

The cleaner is designed to pick up dirt and dust particles. Avoid picking up hard or sharp objects with the cleaner to avoid bag breakage, hose clogging, or possible motor damage.

Service Information

The instructions in this booklet serve as a guide to routine maintenance. If additional service is required, telephone toll free:

USA: 1-800-800-8975

Mexico: (55) 5343-4384

Canada: 1-800-800-8975

If you prefer, you can write to Electrolux Home Care Products North America, Consumer Service, P.O. Box 3900 Peoria, Illinois 61612, USA. In Canada write to Electrolux Home Care Products North America, 866 Langs Drive, Cambridge, Ontario N3H 2N7. Refer to The Sanitaire Limited Warranty for complete service information.



DO NOT OIL the motor at any time. The bearings are permanently lubricated and sealed.

IMPORTANT SAFEGUARDS

When using an electrical appliance, basic precautions should always be followed, including the following:

**READ ALL INSTRUCTIONS
BEFORE USING THIS VACUUM CLEANER.**

WARNING

To reduce the risk of fire, electric shock, or injury:

- Do not use outdoors or on wet surfaces.
- **Do not leave vacuum cleaner when plugged in.** Turn off the switch and unplug the electrical cord when not in use and before servicing.
- Do not allow to be used as a toy. Close attention is necessary when used by or near children.
- Use only as described in this manual. Use only manufacturer's recommended attachments.
- Do not use with damaged cord or plug. If vacuum cleaner is not working as it should, has been dropped, damaged, left outdoors, or dropped into water, return it to a service center before using.
- Do not pull or carry by cord, use cord as a handle, close a door on cord, or pull cord around sharp edges or corners. Do not run vacuum cleaner over cord. Keep cord away from heated surfaces.
- Do not use extension cords or outlets with inadequate current carrying capacity.
- Turn off all controls before unplugging.
- Do not unplug by pulling on cord. To unplug, grasp the plug, not the cord.
- Do not handle plug or vacuum cleaner with wet hands.
- Do not put any object into openings. Do not use with any opening blocked; keep free of dust, lint, hair, and anything that may reduce airflow.
- This vacuum cleaner creates suction. Keep hair, loose clothing, fingers, and all parts of body away from openings and moving parts.
- Do not pick up anything that is burning or smoking, such as cigarettes, matches, or hot ashes.
- Do not use without dust bag in place.
- Belt pulleys can become hot during normal use. To prevent burns, avoid touching the belt pulley when servicing the drive belt.
- Use extra care when cleaning on stairs.
- Do not use to pick up flammable or combustible liquids such as gasoline, or use in areas where they may be present.
- Store your cleaner in a cool, dry area.
- Keep your work area well lighted.
- Unplug electrical appliances before vacuuming them.

SAVE THESE INSTRUCTIONS

HOW TO USE

CAUTION: Moving parts. Make sure on/off switch is in off position before plugging in.

A carpet should be cleaned regularly over heavily traveled areas, and once a week over the entire carpeted area. Vacuum slowly, making several passes (forward and backward) over the carpet, covering small areas at a time. The time required to clean the carpet will depend on several factors—including type of carpet and amount of dirt.

1 Connect Hose

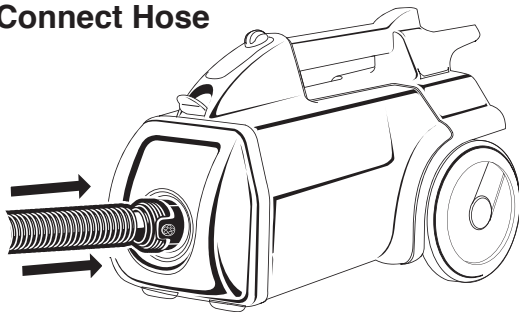

2 Rotate Swivel Hook to release cord

3 Plug In

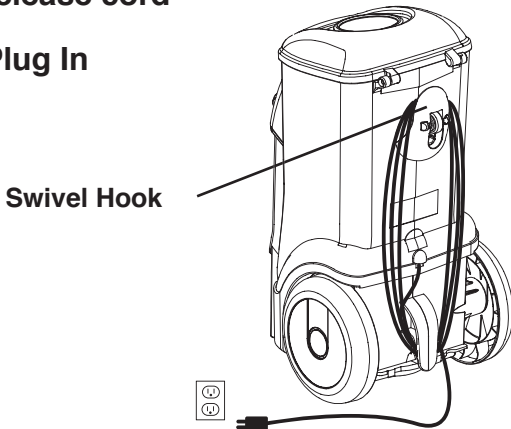

4 Store Tools

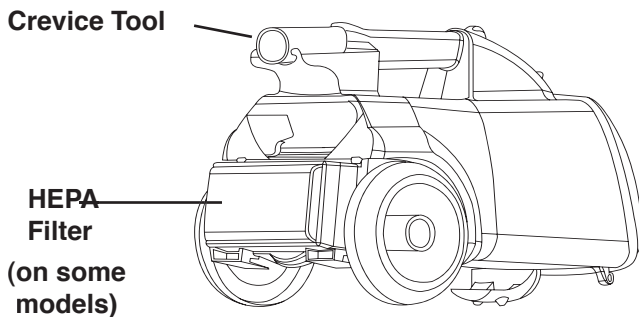

5 Push ON/OFF Switch

(A thermostat automatically shuts the motor off if it overheats, see Automatic Motor Shut-Off)

ON/OFF Switch

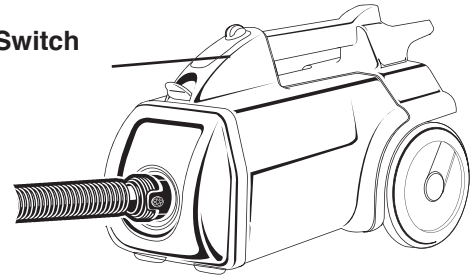

Automatic Motor Shut-Off

To protect from overheating, this vacuum cleaner is equipped with a thermostat which automatically shuts off the motor if it overheats. Should this happen:

1. **Turn off the switch and unplug the cleaner** because the thermostat will allow the cleaner to automatically start running again when the motor cools (approximately 30 minutes).
2. **Check the hose, bag and filter** regularly, as a clogged hose, full bag or dirty filter could cause the motor to overheat.
3. **Call a Eureka Service Station** if the cleaner will not operate after cooling for approximately 30 minutes.

Cleaning Accessories

Attach wands and cleaning tools

(Wands may vary by model)

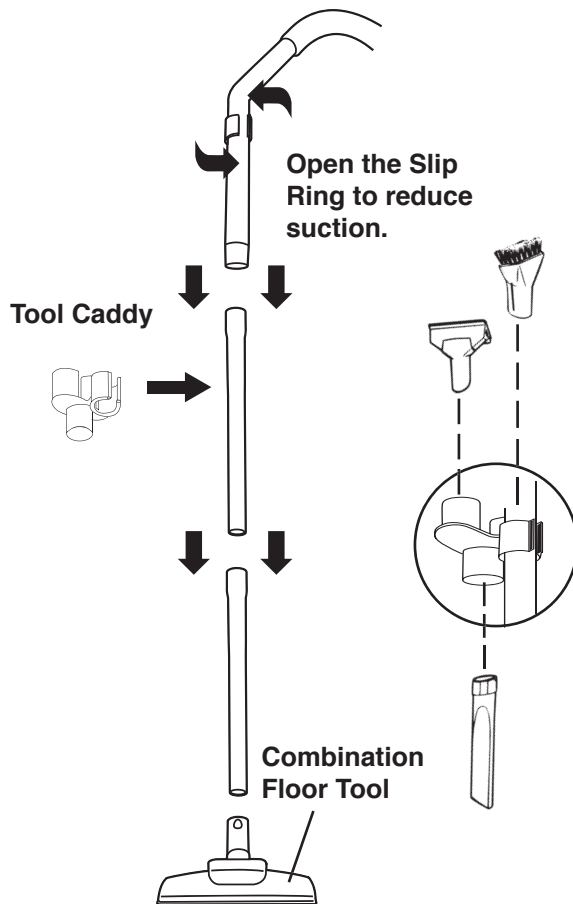

Cleaning Accessories (continued)

Telescoping Wand

To adjust the length of the telescoping wand, hold the wand adjustment collar in one hand while pulling or pushing the wand with the other hand until you have the desired length.

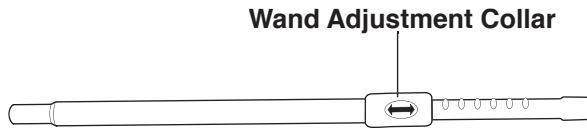

Slip the circular end of an accessory tool onto the end of the hose handle and twist slightly to secure. If additional reach is needed, place a wand on the hose handle first.

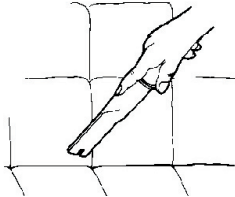

Crevice Tool

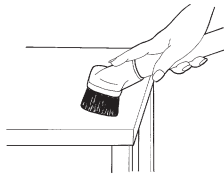

Dusting Brush

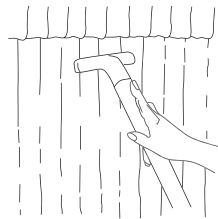

Upholstery Nozzle



***Bare Floor Brush (optional)**

Crevice Tool: For crevices, corners, baseboards, between cushions.

Upholstery Nozzle: For curtains, draperies, cushions, fabrics.

Dusting Brush: For furniture, blinds, books, lamp shades, shelves.

Bare Floor Brush: For any type of hard surface floor.

*May be purchased separately.

HOW TO MAINTAIN

The instructions given in this booklet serve as a guide to routine maintenance. To avoid unnecessary service calls, check the hose, bag and filter often. Clear a clogged hose with the blower, change the bag if it is full, and clean the motor filter when it is dirty.

Disposable Dust Bags and Filters

The dust bag and motor filter play a very important roll in the efficiency of the vacuum cleaner. The purpose of the dust bag is to trap dirt, but at the same time, the paper bag must be porous enough to allow air to pass through. If the bag or the motor filter become clogged, no air can pass through the cleaner and no cleaning can take place regardless of how powerful the unit is. To keep the cleaner operating at maximum efficiency, change the dust bag frequently and clean the filter as needed. Some fine particles can restrict airflow very quickly and will decrease performance even before the bag appears to be full. For that reason, when vacuuming carpet fresheners or cleaners, powder, plaster dust, or similar fine substances, the bag and filter may need to be changed more often.

Look for the **GENUINE** symbol.



FILTERAIRE® Disposable Dust Bag – Style MM, PN 60296A (optional)

Our high filtration bag is a two-layer, disposable bag that combines our standard paper bag with a nonwoven air filter inside. Use a Filteraire dust bag to create a cleaner indoor environment because the bag filters better than our standard bag. The bags are available (three in a package) from your local dealer, or you can call 1-800-282-2886 for other locations. Look for the Genuine Eureka Filteraire dust bag—Style MM.

How to Remove Disposable Dust Bags – Style MM, PN 60295A

CAUTION: Turn off vacuum and unplug the electrical cord before changing dust bag or cleaning motor filter. Never operate the vacuum cleaner without the dust bag or filter.

- 1 Turn off and unplug cleaner.
- 2 Open lid by pushing down hood latch.

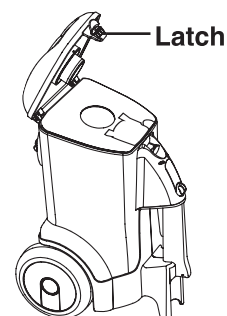

How to Remove Disposable Dust Bags (continued)

- 3 Fold **BAG CLOSURE FLAP** down and push behind rubber seal.

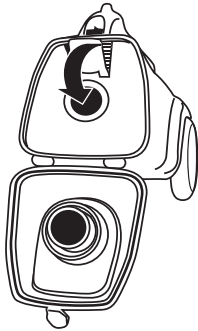

- 4 Insert finger into upper left notch then pull out and remove bag.



How to Install Disposable Dust Bags – Style MM

CAUTION: Turn off vacuum and unplug the electrical cord before changing dust bag or cleaning motor filter. Never operate the vacuum cleaner without the dust bag or filter.

1. Turn off and unplug cleaner.
2. Open bag cover by pushing latch.
3. Clean motor filter by rinsing under warm water and let air dry if heavily soiled.

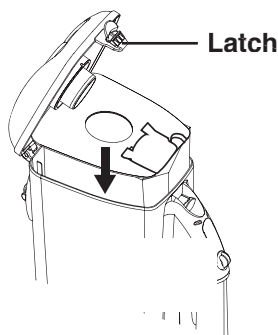

4. Open bag folds slightly.
5. Place bag in cleaner.
6. Tuck bag corners under collar.
7. Swing bag cover closed and push to latch.

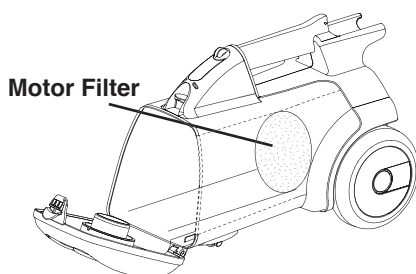

How to Install HEPA Filter, PN 60666A (on some models)

Check the HEPA filter with each disposable dust bag change. Replace twice a year or after every six bag changes.

Upper Filter Tabs

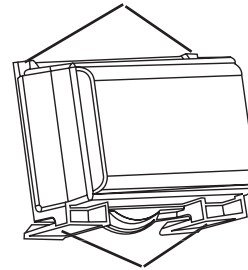

Bottom Clips

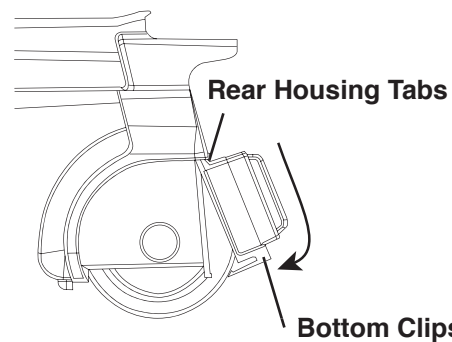

Insert upper filter corner tabs firmly under rear housing tabs and pivot filter down until bottom clips on filter click securely into place on the cleaner.

How to Remove HEPA Filter

Grasp the bottom clips on the filter and pull out and down to release the upper filter tabs from the rear housing tabs on the cleaner.

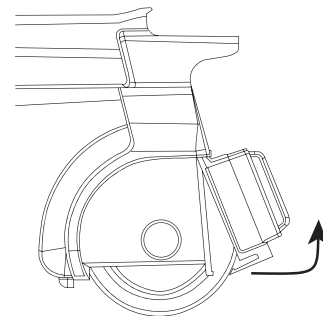

Replace with **GENUINE EUREKA PRODUCT** filter, part number 60666A.

PROBLEM SOLVING

NOTE: Turn OFF the power switch and unplug the electrical cord before servicing.

PROBLEM	CAUSE	SOLUTION
Motor won't start	<input checked="" type="checkbox"/> Electric plug <input checked="" type="checkbox"/> Power switch not turned "ON"	<input type="checkbox"/> Push plug securely into outlet. <input type="checkbox"/> Try another outlet. <input type="checkbox"/> Check circuit breaker. <input type="checkbox"/> Make sure power switch is "ON."
No suction at end of hose	<input checked="" type="checkbox"/> Full paper bag <input checked="" type="checkbox"/> Hose <input checked="" type="checkbox"/> Front cover not latched	<input type="checkbox"/> Replace paper bag. <input type="checkbox"/> Remove any clogs from hose that restrict airflow, then try again. <input type="checkbox"/> Push front cover until it latches firmly.
Reduced suction	<input checked="" type="checkbox"/> Full paper bag <input checked="" type="checkbox"/> Slip ring open <input checked="" type="checkbox"/> Hose	<input type="checkbox"/> Replace paper bag. <input type="checkbox"/> Rotate slip ring on wand until hole is covered. <input type="checkbox"/> Remove any clogs from hose that restrict airflow, then try again.
Cleaner shuts off	<input checked="" type="checkbox"/> Internal safety thermostat trips <input checked="" type="checkbox"/> Cord connection at hose	<input type="checkbox"/> Unplug cleaner and check for obstructions in hose, wands and attachments. <input type="checkbox"/> Check for full paper bag. <input type="checkbox"/> Clean/replace motor filter. <input type="checkbox"/> Check powerhead and hose plugs for proper connection.
General questions	<input checked="" type="checkbox"/> Assembly or related attachments	<input type="checkbox"/> Call 1-800-800-8975 between 8 am to 7:30 pm Monday - Friday, and 10 am to 6:30 pm Saturday, CST. <input type="checkbox"/> Know the model number and serial number when you call.

THE SANITAIRE LIMITED WARRANTY

What This Warranty Covers

Your Sanitaire cleaner is warranted to be free from all defects in material and workmanship in normal household use for a period of two years. The warranty is granted only to the original purchaser and members of his or her immediate household. The warranty is subject to the following provisions.

What This Warranty Does Not Cover

- Parts of the cleaner that require replacement under normal use, such as disposable dust bags, filters, drive belts, light bulbs, and brush roll bristles.
- Damages or malfunctions caused by negligence, abuse, or use not in accordance with the Owner's Guide.
- Defects or damages caused by unauthorized service or the use of other than Genuine Eureka/Sanitaire parts.

What Electrolux Home Care Products North America Will Do

Electrolux Home Care Products North America will, at its option, repair or replace a defective cleaner or cleaner part that is covered by this warranty. As a matter of warranty policy, Electrolux Home Care Products North America will not refund the consumer's purchase price.

Extended Warranty for Upright Cleaner (Only)

The base of the Sanitaire Upright cleaner is warranted for five years from the original date of purchase.

Extended Warranty for SYSTEM_PRO Canisters

The motor for SYSTEM_PRO canister cleaners is warranted for five years from the original date of purchase.

Warranty Registration

Please fill out and return the warranty registration card accompanying your cleaner.

Obtaining Warranty Service

To obtain warranty service you must return the defective cleaner or cleaner part along with proof of purchase to any Sanitaire Authorized Warranty Station. You will find the nearest location in the Yellow Pages, under "Vacuum Cleaners—Service and Repair." Be certain that the Warranty Station is "Sanitaire Authorized." For the location of the nearest Sanitaire Authorized Warranty Station or for service information, telephone toll free:

USA: 1-800-800-8975
Mexico: (55) 5343-4384
Canada: 1-800-800-8975

www.sanitairevac.com

If you prefer, you can write to Electrolux Home Care Products North America, Service Division, P.O. Box 3900, Peoria, Illinois 61612, USA. In Canada write to Electrolux Home Care Products North America, 866 Lings Drive, Cambridge, Ontario N3H 2N7.

If it is necessary to ship the cleaner outside your community to obtain warranty repair, you must pay the shipping charges to the Sanitaire Authorized Warranty Station. Return shipping charges will be paid by the Warranty Station. When returning parts for repair, please include the model, type, and serial numbers from the data plate on the cleaner.

Further Limitations and Exclusions

Any warranty that may be implied in connection with your purchase or use of the cleaner, including any warranty of Merchantability or any warranty for Fitness For A Particular Purpose is limited to the duration of this warranty. Some states do not allow limitations on how long an implied warranty lasts, so the above limitations may not apply to you.

Your relief for the breach of this warranty is limited to the relief expressly provided above. In no event shall Electrolux be liable for any consequential or incidental damages you may incur in connection with your purchase or use of the cleaner. Some states do not allow the exclusion or limitation of incidental or consequential damages, so the above limitation or exclusion may not apply to you.

This warranty gives you specific legal rights. You may also have other rights which vary by state.



Questions & Answers about Genuine Eureka/Sanitaire Products

Q: Why should I use only Genuine Eureka/Sanitaire paper bags, belts, and parts in my Eureka/Sanitaire vacuum cleaner?

A: **Using Genuine Sanitaire Products, which are made to our exacting specifications and engineered with emphasis on quality, performance, and customer satisfaction, ensures the long life and cleaning efficiency of your vacuum cleaner. Overall, this saves you money and helps to keep your home clean.**

Q: How can I be sure I am using only Genuine Eureka/Sanitaire products in my vacuum cleaner?

A: **Typically, packaged products and paper bags can be identified by a Eureka or Sanitaire logo. For further identification assistance, you may call our toll-free number, 1-800-800-8975, for the location of a nearby Eureka/Sanitaire Authorized Warranty Station.**

Q: Are there any differences between "made to fit" or "imitation" and Genuine Eureka/Sanitaire paper bags, belts, and parts?

A: **Yes, there are some very important differences in materials, quality, and reliability. Many customers have mistakenly purchased "imitation" paper bags and parts while thinking they purchased genuine. Unfortunately, many of these customers discovered the differences after they experienced related difficulties.**

For Genuine Sanitaire Value, Accept No Imitations!



ELECTROLUX HOME CARE PRODUCTS NORTH AMERICA

Bloomington, Illinois 61701