

MINI-EXTRACTOR

Operating instructions (ENG)

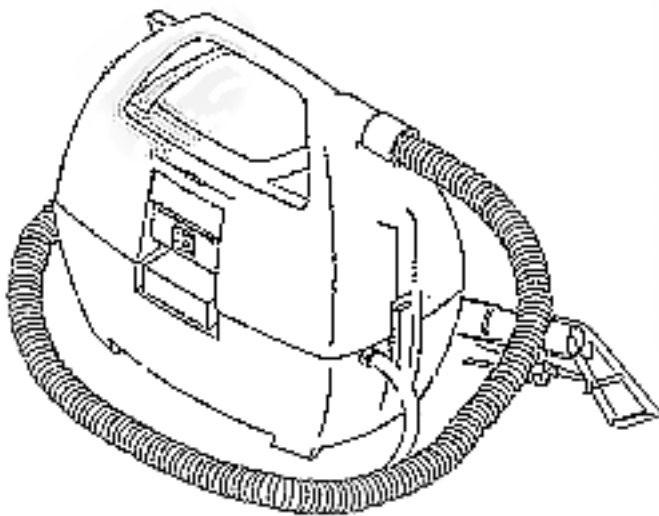

Read these instructions before using the machine.

86221950-G

02/10/11



120V MODELS
ONLY



Machine Data Label

Model: _____

Date of Purchase: _____

Serial Number: _____

Dealer: _____

Address: _____

Phone Number: _____

Sales Representative: _____

Machine Data Label2
Table of Contents3
How to Use This Manual4

Safety

IMPORTANT SAFETY INSTRUCTIONS5
HAZARD INTENSITY LEVEL7
Grounding Instructions9

Operations10
Set-up and Operation10

Maintenance12
Daily Maintenance12
Periodic Maintenance12
Shut Down and Storage12
Solution Pump Replacement12
Vacuum Motor Replacement13
Troubleshooting14

Parts

Extractor 16
Solution Pump. 18
Wiring Diagram 20

Options

Hand Tool 24
Mini Cart 26
Cart 28
Suggested Spare Parts 30
Serial Numbers 31

How to Use This Manual

This manual contains the following sections:

- HOW TO USE THIS MANUAL
- SAFETY
- OPERATIONS
- MAINTENANCE
- PARTS LIST

The HOW TO USE THIS MANUAL section will tell you how to find important information for ordering correct repair parts.

Parts may be ordered from authorized dealers. When placing an order for parts, the machine model and machine serial number are important. Refer to the MACHINE DATA box which is filled out during the installation of your machine. The MACHINE DATA box is located on the inside of the front cover of this manual.

Model: _____
Date of Purchase: _____
Serial Number: _____
Dealer: _____
Address: _____
Phone Number: _____
Sales Representative: _____

The model and serial number of your machine is on the back underside of machine.

The SAFETY section contains important information regarding hazard or unsafe practices of the machine. Levels of hazards is identified that could result in product or personal injury, or severe injury resulting in death.

The OPERATIONS section is to familiarize the operator with the operation and function of the machine.

The MAINTENANCE section contains preventive maintenance to keep the machine and its components in good working condition.

The PARTS LIST section contains assembled parts illustrations and corresponding parts list. The parts lists include a number of columns of information:

REF - column refers to the reference number on the parts illustration.

PART NO. - column lists the part number for the part.

PRV NO. - Reference No.

QTY - column lists the quantity of the part used in that area of the machine.

DESCRIPTION - column is a brief description of the part.

SERIAL NO. FROM - If this column has an (*) and a Reference number, see the SERIAL NUMBERS page in the back of your manual. If column has two asterisk (**), call manufacturer for serial number.

The serial number indicates the first machine the part number is applicable to. The main illustration shows the most current design of the machine.

When a boxed illustration is shown, it displays the older design.

NOTES - column for information not noted by the other columns.

NOTE: If a service or option kit is installed on your machine, be sure to keep the KIT INSTRUCTIONS which came with the kit. It contains replacement parts numbers needed for ordering future parts.

NOTE: The number on the lower left corner of the front cover is the part number for this manual.

IMPORTANT SAFETY INSTRUCTIONS

When using an electrical appliance, basic precaution must always be followed, including the following:



READ ALL INSTRUCTIONS BEFORE USING THIS MACHINE.

To reduce the risk of fire, electric shock, or injury:

Use only indoors. Do not use outdoors or expose to rain.

Use only as described in this manual. Use only manufacturer's recommended components and attachments.

If the machine is not working properly, has been dropped, damaged, left outdoors, or dropped into water, return it to an authorized service center.

Do not operate the machine with any openings blocked. Keep openings free of debris that may reduce airflow.

This machine is not suitable for picking up hazardous dust.

Machine can cause a fire when operating near flammable vapors or materials. Do not operate this machine near flammable fluids, dust or vapors.

During operation, attention shall be paid to other persons, especially children.

When leaving unattended, secure against unintentional movement.

The machine shall only be operated by instructed and authorized persons.

When leaving unattended, switch off or lock the main power switch to prevent unauthorized use.

Do not handle the plug or machine with wet hands.

Do not unplug machine by pulling on cord. To unplug, grasp the plug, not the cord.

Do not use with damaged cord or plug. Follow all instructions in this manual concerning grounding the machine.

Do not pull or carry by cord, use cord as a handle, close a door on cord, or pull cord around sharp edges or corners.

Do not pull/run machine over cord. Keep cord away from heated surfaces.

Connect to a properly grounded outlet. See Grounding Instructions.

SAVE THESE INSTRUCTIONS

IMPORTANTES MESURES DE SÉCURITÉ

L'utilisation d'un appareil électrique demande certaines précautions:

LIRE TOUTES LES INSTRUCTIONS AVANT DE FAIRE FONCTIONNER (CET APPAREIL).

⚠ AVERTISSEMENT: Pour réduire les risques d'incendie, de chocs électriques, ou d blessures :

N'utiliser cette machine qu'en intérieur. Ne jamais l'utiliser à l'extérieur ou dans la pluie.

N'utiliser cette machine que comme décrit dans le présent manuel. N'utiliser que les composants et les accessoires conseillés par le fabricant.

Lorsque la machine ne fonctionnant pas correctement, a fait l'objet d'une chute ou d'une détérioration, a été laissée à l'extérieur, est tombée dans l'eau, la retourner au centre de service agréé.

Ne pas opérer la machine lorsque les conduits de ventilation sont bloquées. Débarrasser les débris des conduits, car ils peuvent réduire l'écoulement d'air.

Cette machine n'est pas adaptée au ramassage de poussières dangereuses.

Cette machine peut provoquer un incendie lorsqu'elle est utilisée près de vapeurs ou de matériaux inflammables. Ne pas l'utiliser près de liquides, de poussières ou de vapeurs inflammables.

Cette machine est destinée à un usage commercial. Elle est recommandée davantage pour les domaines hôtelier, scolaire, hospitalier, industriel ou pour les bureaux, les chaînes de magasin, que pour un usage domestique normal.

L'entretien et les réparations de la machine doivent être effectuées par un personnel qualifié.

Durant la manoeuvre de la machine, prendre garde aux personnes environnantes et notamment aux enfants.

Lorsque la machine est laissée sans surveillance, s'assurer qu'elle ne se déplace pas de manière accidentelle.

Cette machine ne doit être manoeuvrée que par un personnel expérimenté et qualifié.

Lorsque la machine est laissée sans surveillance, la mettre hors tension ou verrouiller l'interrupteur principal afin d'empêcher un emploi non autorisé.

Ne pas toucher la fiche ou l'appareil lorsque vos mains sont humides.

Ne pas débrancher en tirant sur le cordon. Tirer plutôt la fiche.

Ne pas utiliser si le cordon ou la fiche est endommagé

Ne pas tirer soulever ou traîner l'appareil par le cordon. Ne pas utiliser le cordon comme une poignée, le coincer dans l'embrasure d'une porte ou l'appuyer contre des arêtes vives ou des coins.

Ne pas faire rouler l'appareil sur le cordon. Garder le cordon à l'écart des surfaces chaudes.

Cet appareil ne doit être connecter qu'a des prises ayant une sortie de terre. Se reporter aux instructions de mise à la terre.

CONSERVER CES INSTRUCTIONS

The following symbols are used throughout this guide as indicated in their descriptions:

HAZARD INTENSITY LEVEL

There are three levels of hazard intensity identified by signal words -WARNING and CAUTION and FOR SAFETY. The level of hazard intensity is determined by the following definitions:



WARNING - Hazards or unsafe practices which COULD result in severe personal injury or death.



CAUTION - Hazards or unsafe practices which could result in minor personal injury or product or property damage.

FOR SAFETY: To Identify actions which must be followed for safe operation of equipment.

Report machine damage or faulty operation immediately. Do not use the machine if it is not in proper operating condition. Following is information that signals some potentially dangerous conditions to the operator or the equipment. Read this information carefully. Know when these conditions can exist. Locate all safety devices on the machine. Please take the necessary steps to train the machine operating personnel.

FOR SAFETY:

DO NOT OPERATE MACHINE:

Unless Trained and Authorized.

Unless Operation Guide is Read and understood.

In Flammable or Explosive areas.

In areas with possible falling objects.

WHEN SERVICING MACHINE:

Avoid moving parts. Do not wear loose clothing; jackets, shirts, or sleeves when working on the machine. Use manufacturer approved replacement parts.

Les symboles ci-dessous sont utilisés à travers ce manuel comme illustré dans leurs descriptions :

DEGRÉS DE RISQUES EN CAS DE DANGER

Il existe trois degrés de risques identifiés par les termes signalétiques -**AVERTISSEMENT** et **ATTENTION** et **POUR VOTRE SÉCURITÉ**. Le degré de risque est défini de la manière suivante :

▲ AVERTISSEMENT:

AVERTISSEMENT - Dangers ou méthodes dangereuses qui **POURRAIENT** provoquer de graves blessures ou entraîner la mort.

▲ ATTENTION:

ATTENTION - Dangers ou méthodes dangereuses qui pourraient provoquer des blessures légères ou une détérioration du produit ou des biens immobiliers.

POUR VOTRE SÉCURITÉ : ce signe permet d'identifier les mesures de précaution à prendre pour assurer un bon fonctionnement du matériel.

Rendre compte immédiatement d'une défaillance ou d'une détérioration de la machine. Ne pas utiliser la machine si celle-ci ne fonctionne pas correctement. Lire soigneusement les informations ci-dessous signalant certains dangers potentiels pour l'opérateur de la machine. L'opérateur doit être absolument au courant de ces dangers potentiels. Localiser tous les dispositifs de sécurité sur la machine. Il est conseillé de prendre les mesures nécessaires pour former le personnel opérateur.

POUR VOTRE SÉCURITÉ :

NE PAS MANOEUVRER LA MACHINE :

Lorsqu'on n'est pas expérimenté ou qualifié.

Lorsque le guide d'utilisation n'est pas été lu ou compris.

Dans des zones inflammables ou explosives.

Dans des zones où des objets peuvent tomber.

LORS DE L'ENTRETIEN DE LA MACHINE :

Éviter les parties amovibles. Ne pas porter de vêtements amples, tels que des vestes, des chemises ou des vêtements avec manches lors de l'utilisation de la machine. Utiliser les pièces détachées Windsor homologuées.

Grounding Instructions

THIS PRODUCT IS FOR COMMERCIAL USE ONLY.

ELECTRICAL:

In the USA this machine operates on a standard 15 amp 115V, 60 hz, A.C. power circuit. The amp, hertz, and voltage are listed on the data label found on each machine. Using voltages above or below those indicated on the data label will cause serious damage to the motors.

EXTENSION CORDS:

If an extension cord is used, the wire size must be at least one size larger than the power cord on the machine, and must be limited to 50 feet (15.5m) in length.

GROUNDING INSTRUCTIONS:

This appliance must be grounded. If it should malfunction or break down, grounding provides a path of least resistance for electric current to reduce the risk of electric shock. This appliance is equipped with a cord having an equipment-grounding conductor and grounding plug. The plug must be inserted into an appropriate outlet that is properly installed and grounded in accordance with all local codes and ordinances.

This appliance is for use on a nominal 120-volt circuit, and has a grounded plug that looks like the plug in "Fig. A". A temporary adaptor that looks like the adaptor in "Fig. C" may be used to connect this plug to a 2-pole receptacle as shown in "Fig. B", if a properly grounded outlet is not available. The temporary adaptor should be used only until a properly grounded outlet (Fig. A) can be installed by a qualified electrician. The green colored rigid ear, lug, or wire extending from the adaptor must be connected to a permanent ground such as a properly grounded outlet box cover. Whenever the adaptor is used, it must be held in place by a metal screw.

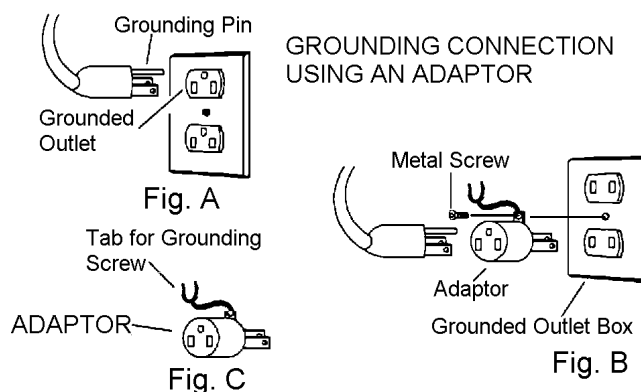

Note: Adaptors are not allowed in Canada.

⚠ WARNING:

Improper connection of the equipment-grounding conductor can result in a risk of electric shock. Check with a qualified electrician or service person if you are in doubt as to whether the outlet is properly grounded. Do not modify the plug provided with the appliance - if it will not fit the outlet, have a proper outlet installed by a qualified electrician.

⚠ AVERTISSEMENT:

Le raccordement incorrect du conducteur de terre d'équipement peut entraîner des risques d'électrocution. Vérifiez auprès d'un électricien qualifié ou d'un responsable de l'entretien si vous avez quelque doute que ce soit quant au raccordement à la terre de votre prise murale. Ne modifiez pas la fiche fournie avec l'appareil : si elle ne correspond pas à la prise murale, faites installer une prise adéquate par un électricien qualifié.

Set-up and Operation

1. Upon removing your new mini-extractor from the box, loosen the latch at back end of the machine that secures the recovery tank to the solution tank. Remove the recovery tank from the solution tank.
2. Pour clean, hot water to the indicated fill line of the solution tank. To avoid possible tank distortion, water temperature must not exceed 140 F (60C).
3. Add a non-foaming cleaning solution concentrate, for use in hot water extractors at the proportions noted on the container (See list below), into solution tank.
4. Place the recovery tank back onto the solution tank and refasten the latch.
5. Plug the power cord into grounded outlet (See GROUNDING INSTRUCTIONS).
6. Connect the vacuum and cleaning tool hoses to the extractor. This unit is equipped with an 1/8" male quick connect for solution hose attachment and a 1" ID vacuum hose hookup. Insure that the female solution hose coupler is securely locked onto the male coupler on the extractor.
7. Turn switch ON. This switch operates both the vacuum motor and the water pump. NOTE: The pump is an oscillating pump and should not be run dry for extended periods of time. This may cause damage to your pump, therefore voiding your warranty.
8. Squeeze the solution lever on the cleaning tool to spray cleaning solution and place the vacuum head on the surface to be cleaned. Normally, chemical is applied on the push stroke while vacuuming is done on the pull stroke. For heavily soiled carpets the hand tool may be used in the scrubbing manner, applying chemical in both the push and pull stroke. Always finish up an area with a vacuum pull stroke.
9. When cleaning, be sure to monitor the level of recovered solution in the recovery tank. When the solution reaches the FULL mark, shut off the extractor, loosen the latches and empty the recovery tank.

NOTE: Dispose of waste in a proper manner which would not violate any Local, State or Federal law.

⚠ CAUTION:

Operating vacuum with solution above the FULL mark could draw water directly into the vac motor. This will cause damage to the motor, therefore voiding your warranty.

⚠ ATTENTION:

L'utilisation de l'aspirateur avec la solution dépassant la marque FULL (PLEIN) pourrait entraîner l'eau directement dans le moteur d'aspiration. Cela pourrait endommager le moteur et annuler votre garantie. .

⚠ CAUTION:

Always Test Upholstery/carpet For Color Fastness In An Inconspicuous Place. Also, To Avoid Prolonged Drying Times, Do Not Spray Too Much Solution In Any One Area.

⚠ ATTENTION:

Testez Toujours La Solidité Des Teintures De La Tapisserie / Du Tapis Dans Un Endroit Peu Visible. Aussi, Pour Éviter Les Temps De Séchage Prolongés, Ne Pulvériser Pas Trop De Solution Dans Un Seul Endroit.

⚠ CAUTION:

Always use defoamer if foaming occurs. Foam will suspend large particles which may damage vacuum as well as allow liquid into the vacuum motor without activating the float shutoff.

⚠ ATTENTION:

Utilisez toujours des anti-mousses, en cas de formation de mousse. La mousse suspendra les grosses particules qui peuvent endommager l'aspirateur et laissera le liquide s'écouler dans le moteur de l'aspirateur sans entraîner l'arrêt du flotteur.

⚠ WARNING:

To prevent possible disease hazard, before attempting to clean bodily fluids spills, you must kill any viruses, germs or bacteria present in the bodily fluid.

⚠ ATTENTION:

Pour éviter tout risque possible de maladie, avant de tenter de nettoyer les déversements de fluides corporels, il faut tuer tous les virus, germes ou bactéries présents dans le fluide corporel.

SUITABLE CHEMICALS	IMCOMPATIBLE CHEMICALS
Alkalis	Aldehydes
Clorox II Bleach*	Aromatic Hydrocarbons
Defoaming Agents	Butyls
Detergents	Carbon Tetrachloride
Hydroxides	Clorox*
Oxygen Bleaches	Chlorinated Bleaches
Soaps	Chlorinated Hydrocarbons
Sta-Puf Fabric Softener*	D-Limonene
Vinegar	Lysol*
-	Methyls (MEK)
-	Perchloroethylene (perc)
-	Phenols
-	Trichloroethylene

*Registered Trademark

Daily Maintenance

Follow same procedure for Shut Down and Storage.

Periodic Maintenance

1. Twice a month, flush a white vinegar solution (one quart vinegar to two gallons water) or anti-browning solution (mixed as directed) through the extractor. This will prevent build-up of alkaline residue in the system.
2. If spray jet becomes clogged, remove the spray tip, wash it thoroughly, and blow dry.

NOTE: Do Not Use Pins, Wire, Etc. To Clean Nozzle As This Could Destroy The Spray Pattern.

3. Apply silicone lubricant to solution nipple.
4. Periodically inspect all hoses, electrical cable and connections on your machine. Frayed or cracked hoses should be repaired or replaced to eliminate vacuum or solution pressure loss. If the cable insulation on the power cord is broken or frayed, repair or replace immediately. Don't take chances with electrical fire or shock.

⚠ WARNING:

Before making any adjustments or performing any maintenance to your machine, disconnect the power cord from the electrical source.

⚠ AVERTISSEMENT:

Retirez le cordon d'alimentation de la machine de la source électrique avant de procéder à des réparations ou des ajustements de la machine.

Shut Down and Storage

1. Turn Switch OFF. Empty recovery tank completely and rinse several times to remove any dirt or debris that may be left behind.
2. Tip the solution tank over a sink to drain any unused cleaning solution and rinse with clean water to remove any suds left behind by the cleaning chemicals.

NOTE: Dispose of waste in a proper manner which would not violate any Local, State or Federal law

3. Run a small amount of clean water through pump if chemicals were used. This will help insure the life of your pump.
4. Check the spray jet on the cleaning tool for full spray pattern and inspect vac head for any obstructions. Also make sure to clean the filter cap attached to portal cover of any debris that may have been trapped during cleaning.
5. Remove as much moisture from system before storing in cold climates. Excess water may freeze during storage and crack internal components, causing damage to the unit.

⚠ WARNING:

Only qualified maintenance personnel are to perform repairs.

⚠ AVERTISSEMENT:

Seul le personnel d'entretien qualifié peut effectuer des réparations.

Solution Pump Replacement

1. Turn off all switches and unplug the machine.
2. Unlatch and remove recovery tank.
3. Unfasten screws holding vacuum motor housing to solution tank.
4. Unfasten screws holding pump plate to bottom of solution tank.
5. Remove solution hoses from fittings on pump.
6. Remove pump from brackets and remove fittings and grounding wire.
7. Reverse process to install new replacement pump.

Vacuum Motor Replacement

1. Turn off all switches and unplug machine.
2. Unlatch and remove recovery tank.
3. Unfasten screws holding vacuum motor retainer to vacuum motor housing
4. Lift vacuum motor from vacuum motor housing. Locate the vacuum motor wires and disconnect at the connector.
5. Remove vacuum motor.
6. Reverse process to install vacuum motor replacement.

WARNING: The green ground wire must be attached for safe operation. See wiring diagram.

AVERTISSEMENT: Le fil à la terre vert doit être attaché pour un fonctionnement en toute sécurité. voir le schéma de câblage.

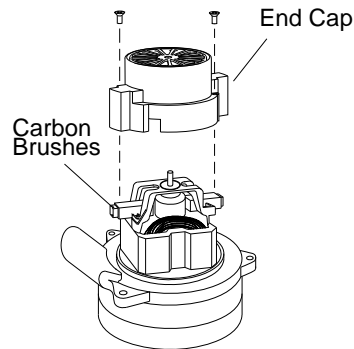

If armature commutator is grooved, extremely pitted or not concentric, the motor will need to be replaced or sent to a qualified service center.

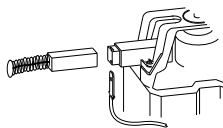

Important:

These brushes wear quicker as the length shortens due to increased heat. Spring inside brush housing will damage motor if brushes are allowed to wear away completely.

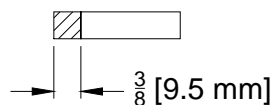

Periodically check the length of the carbon brushes. Replace both carbon brushes when either is less than 3/8" (9.5mm) long.

Troubleshooting

PROBLEM	CAUSE	SOLUTION
Little or no solution flow	Clogged spray jet on cleaning tool	Remove and clean jets
	Faulty pump	Check and replace pump
	Incorrectly attached solution hose	Ensure solution hose coupler is securely attached to the coupler on the solution tank
Loss of vacuum/Solution recovery	Incorrectly attached vacuum hose	Ensure Vacuum hose is pushed completely onto the recovery tank inlet.
	Obstruction in cleaning tool	Inspect for and remove any debris.
	Recovery tank is not securely mounted on the solution tank	Tighten latch on either end of the machine

PARTS

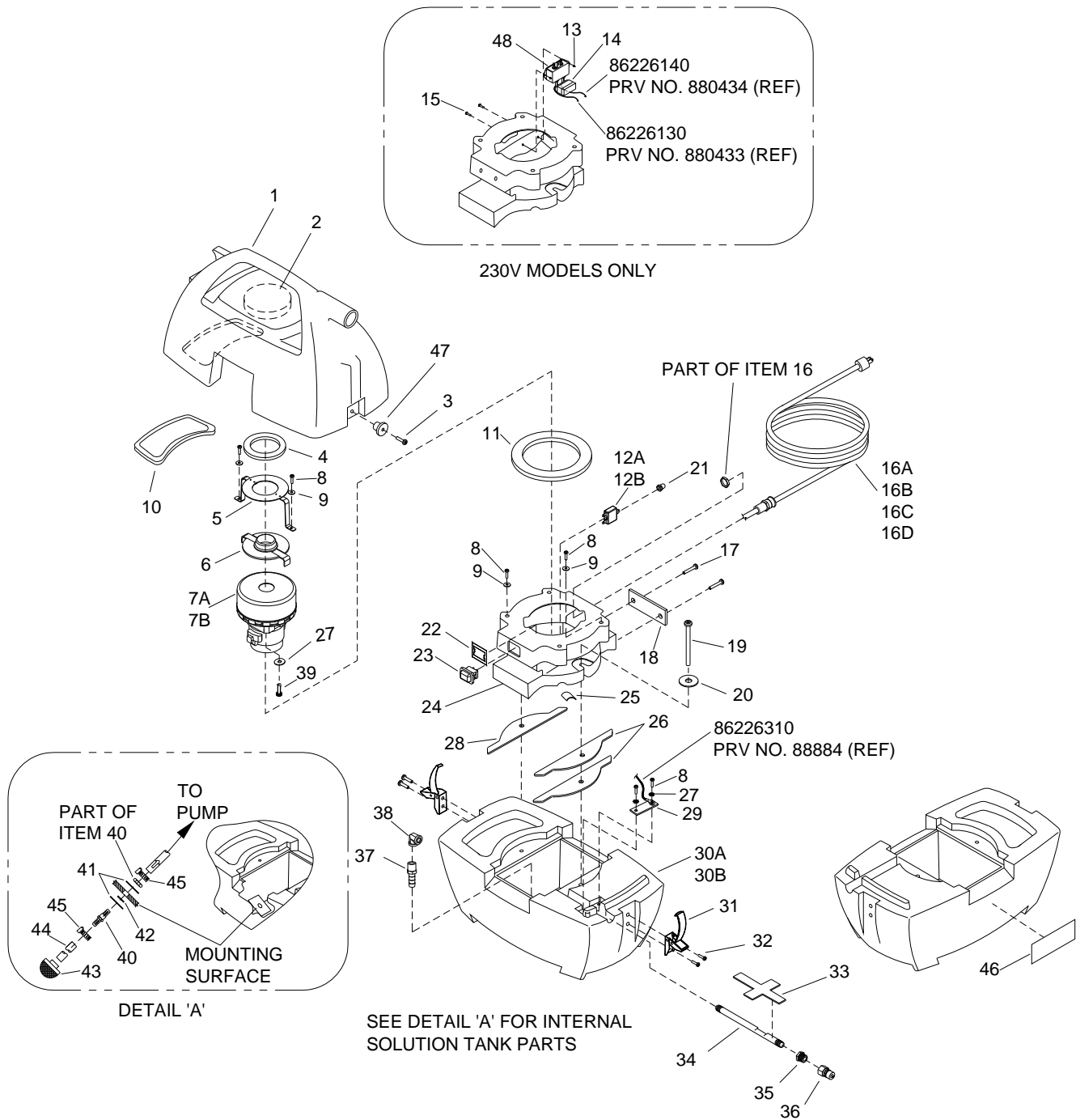

REF	PART NO.	QTY	DESCRIPTION	SERIAL NO. FROM	NOTES:
1	86225200	1	TANK, RECOVERY		
2	86236520	1	FOAM, 4.00 OD X 1.0 THICK		
3	86223730	2	SCREW, 8-32 X 1/2 FHMS BLK PLTD		
4	86237440	1	GASKET, 4.06 X 2.50 X .38		
5	86223440	1	RETAINER, VAC MOTOR		
6	86217310	1	COVER, VAC MOTOR		
7A	86258440	1	VAC MOTOR, 120V 2ST LNP		
7B	86225500	1	VAC MOTOR, 230V 2ST LNP		230V
8	86274290	6	SCR, 10-32 X 3/8 PPHMS SS		
9	86225770	4	WASHER, M6 X 12.5 FLAT SS		
10	86237410	1	GASKET, SPOTTER RECOVERY		
11	86237420	1	GASKET, 4.0 X 5.5" X .25 PORON		
12A	86215670	1	BREAKER, 8A VDE CIRCUIT		
12B	86215710	1	BREAKER, 5A VDE CIRCUIT		
13	86010690	2	WASHER, 1/8 RIVET BACKUP		
14	86261160	1	CAPACITOR ASM, EMI SPOTTER		230V
15	86136540	3	RIVET, M4 X 14 MM		
16A	86217060	1	CORD ASM, 14 X 3 25' YLW SPOTTER		U.S. MACHINE
16B	86217040	1	CORD ASM, UK SPOTTER		UK MACHINE
16C	86217070	1	CORD ASM, EURO SPOTTER		EUROPE MACHINE
16D	86217080	1	CORD ASM, AUST SPOTTER		AUSTRALIA MACHINE
17	86136550	2	RIVET, M3 X 12 MM		
18	86079650	1	PLATE, DATA LABEL		
19	86275870	2	SCREW, 1/4-20 X 1.5 PHMS PLTD		
20	86225760	2	WASHER, M8 X 22 FLAT PLTD		
21	86002010	1	BOOT, 3/8 CIRCUIT BREAKER		
22	86233510	1	CLIP, SWITCH RETAINING		
23	86225110	1	SWITCH, DPST 250V 16(4) SPLASH		
24	86219310	1	HOUSING, VAC		
25	86237460	1	GASKET, .31 x .75 x 1.98		
26	86237450	2	GASKET, VAC HOUSING 3/16"		
27	86010640	3	WASHER, #10 EXT. TOOTH LOCK		
28	86218030	1	GASKET, VAC HOUSING 3/8"		
29	86068560	1	BRACKET, NIPPLE		
30A	86225190	1	TANK, SOLUTION		
30B	86225220	1	TANK, SOLUTION SPOTTER GRAY		
31	86246180	2	LATCH, PRESTO TANK		
32	86006520	4	SCREW, 8-32 X 3/8 PPHMS SS		
33	86218160	1	GASKET, GROUND WIRE		
34	86247740	1	NIPPLE, 1/4 X 6.0 BRASS		
35	86227220	1	ADPTR, 1/8 MPT X 1/4 FPT BRASS		
36	86200820	1	NIPPLE, 1/8 FPT QD MALE BRASS		
37	86197580	1	HOSEBARB, 1/4 MPT X 3/8		
38	86197370	1	ELBOW, 1/4 FPT X 1/4 FPT		
39	86288450	1	SCR, M4.8 X 10 HHTF TYPE B		
40	86258310	1	BULKHEAD, UNION		
41	86279320	2	WASHER, .52 ID X .875 OD		
42	86248090	1	O-RING, .500 ID X .688 OD X .103		
43	86007700	1	STRAINER, 80 MESH X 3/8 FPT		
44	86219010	1	HOSE, 3/8 ID SGLBRD RBR X 5"		
45	86233150	2	CLAMP, HOSE		
46	86220140	1	LABEL, WARNING		
47	86241790	2	KEEPER, PRESTO LATCH		
48	86236010	1	FILTER, EMI 250V 6A 1.75MM		230V

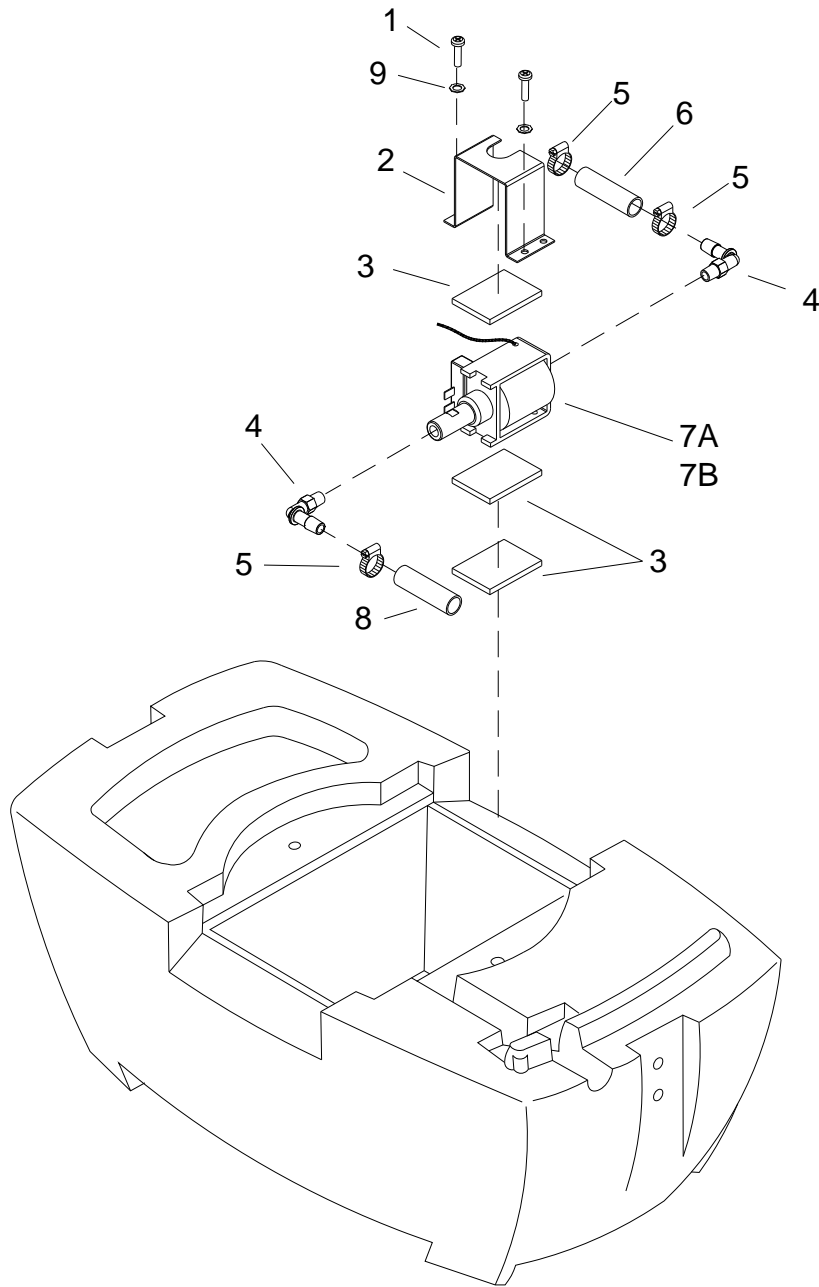

REF	PART NO.	QTY	DESCRIPTION	SERIAL NO. FROM	NOTES:
1	86275710	2	SCREW, 10-32 X 3/8 PPH EX-SEMS		
2	86068690	1	BRACKET, SOLENOID PUMP		
3	86237530	3	GASKET, TUBE SEAL		
4	86197590	2	HOSEBARB, 1/8 MPT 3/8 90°		
5	86233150	3	CLAMP, HOSE		
6	86240290	1	HOSE, 3/8ID WIREBOUND X 2.6"		
7A	86201110	1	PUMP, 110/120V 60HZ FLOJET		
7B	86201120	1	PUMP, 220/240V 50 HZ FLOJET		230V
8	86281310	1	HOSE, 3/8ID WIREBOUND X 8.8"		
9	86010640	2	WASHER, #10 EXT. TOOTH LOCK		

REF	PART NO.	QTY	DESCRIPTION	SERIAL NO. FROM	NOTES:
1	86226310	2	WIRE, 14" GRN/18 76008 X 76008		
2	86226100	1	WIRE, 13" BLK/14 76050 X 76029		
3	86226110	1	WIRE, 13" WHT/14 76050 X 76059		
4	86226120	1	WIRE, 9" BLK/14 76029 X 76029		
5	86226130	1	WIRE, 9" BLK/14 76050 X 76029		
6	86226140	1	WIRE, 9" WHT/14 76050 X 76029		
7	86226160	1	WIRE, 10" GRN/14 76022 X 76010		
8	86226150	1	WIRE, 12" BLK/14 76029 X 76022		
9	86006770	1	SCR, 10-32 X 1/4 PHTR PLTD		
10	86010640	1	WASHER, #10 LOCK EXT STAR SS		

Notes:

OPTIONS

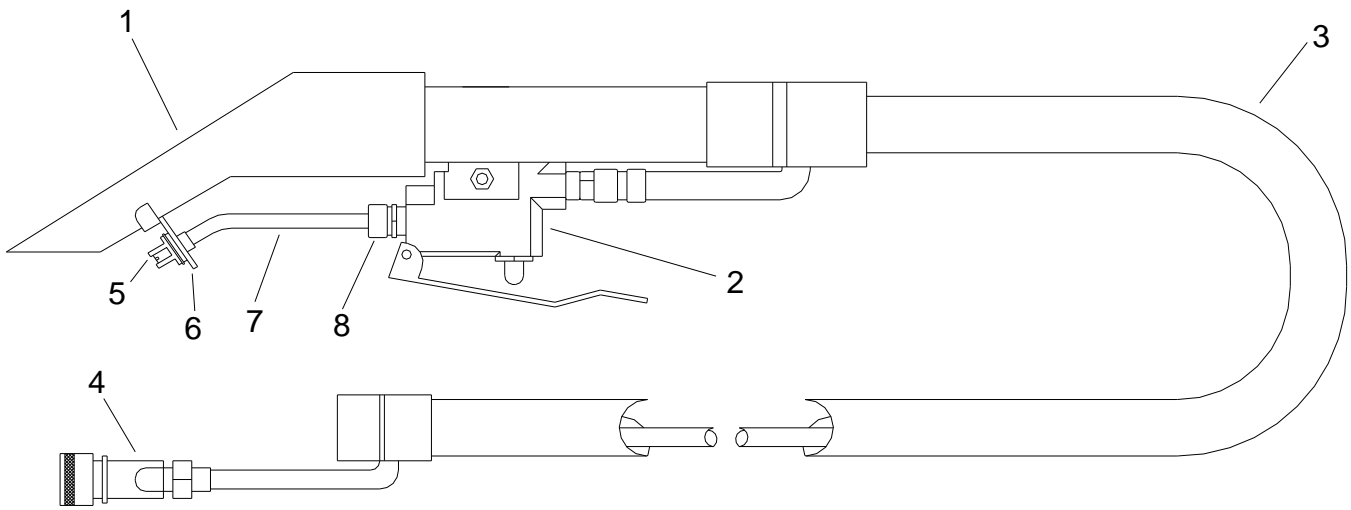

REF	PART NO.	QTY	DESCRIPTION	SERIAL NO. FROM	NOTES:
1	86219340	1	HOUSING, HANDTOOL SPOTTER		
2	86225670	1	VALVE ASM, SPOTTER OKA		
3	86219020	1	HOSE ASM, VAC/SOLUTION		
4	86200810	1	NIPPLE, 1/8 FPT QD FEM BRASS		
5	86219570	1	JET, ASM W/O RING		
6	86223100	1	PLATE, RETAINER W/HARDWARE		
7	86221910	1	MANIFOLD, SPOTTER		
8	86218000	1	FTTG, 1/8MPT X 3/16 COMP		
-	86218790	-	HAND TOOL, SPOTTER		ENTIRE ASSEMBLY AS KIT

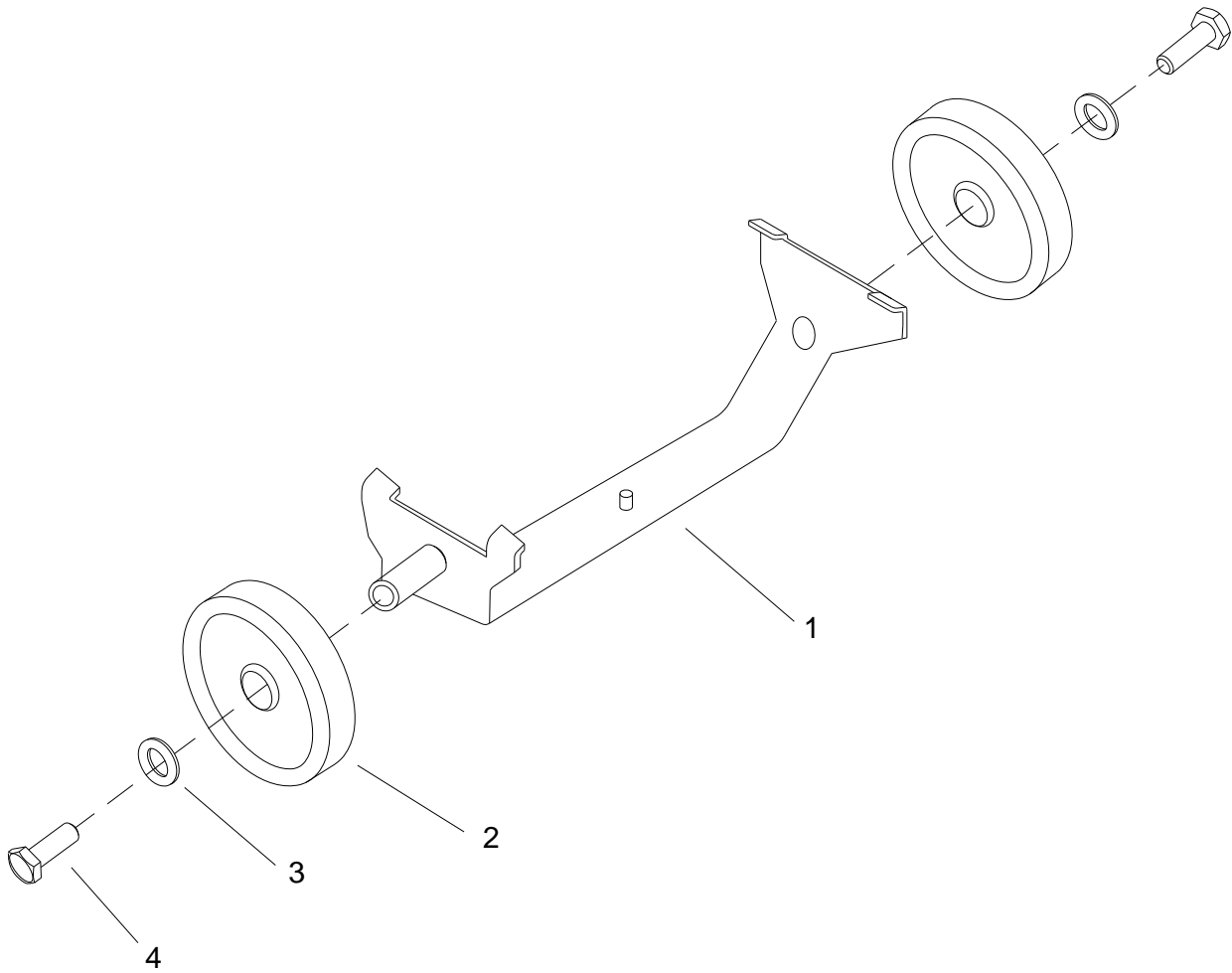

REF	PART NO.	QTY.	DESCRIPTION	SERIAL NO.FROM	NOTES:
1	86222950	1	PLATE, WELDMENT		
2	86259770	2	WHEEL, 5"D X 1" X .5" ID GRY		
3	86137280	2	WASHER, M8 FLAT DIN125A PLT		
4	86136640	2	SCR, M8 X 20 HHMS PLTD		
-	86222030	-	MINI CART		ENTIRE ASSEMBLY AS KIT

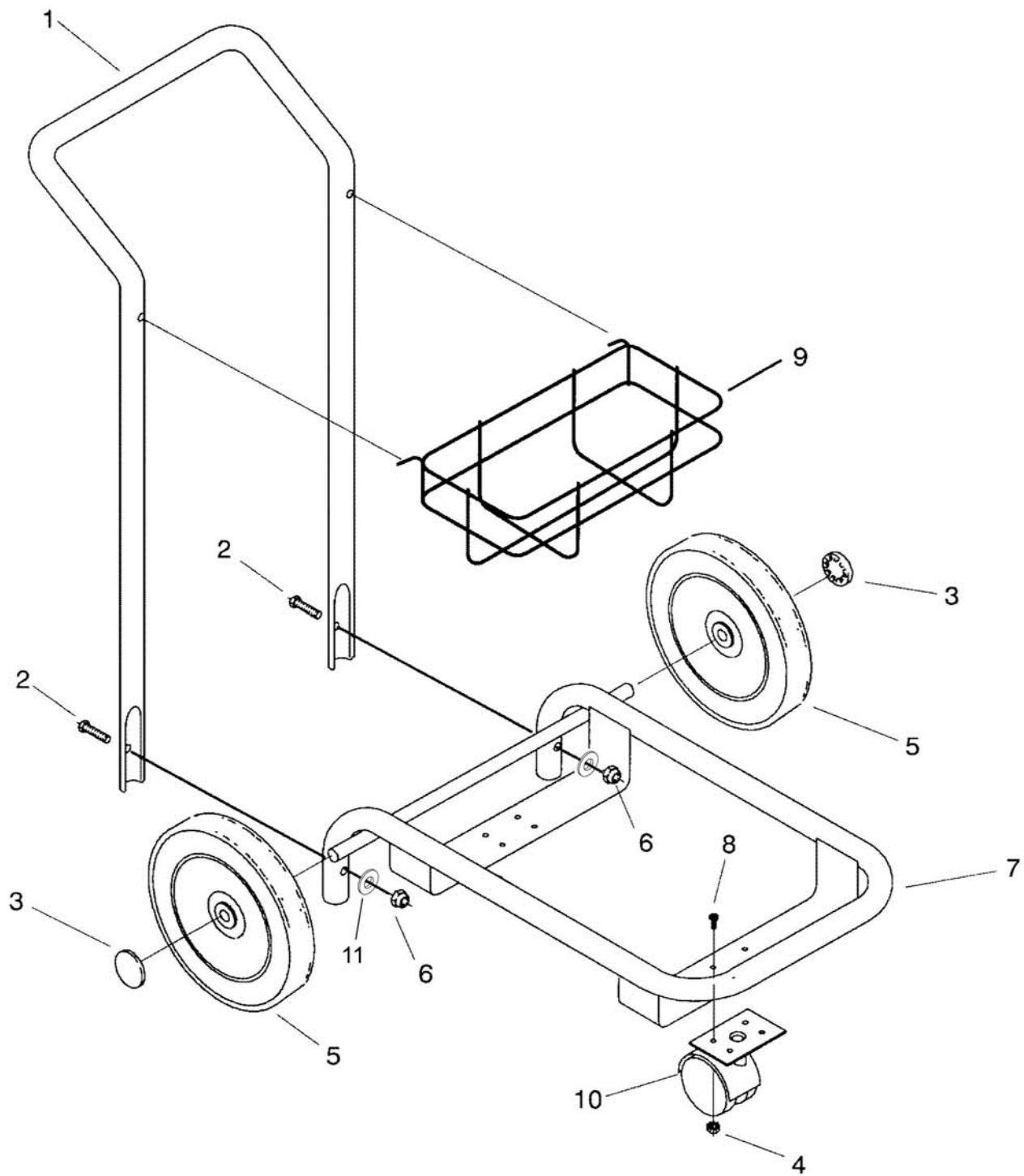

REF	PART NO.	QTY	DESCRIPTION	SERIAL NO. FROM	NOTES:
1	86089270	1	TUBE, CART HANDLE		
2	86273740	2	SCREW, 1/4-20 X 1.5 TAP PLTD.		
3	86271380	2	NUT, 1/2 STAR LOCK PUSH-ON		
4	86005700	4	NUT, 10-32 HEX W/ STAR WASHER		
5	86259970	2	WHEEL, 8" GREY		
6	86005680	2	NUT, 1/4-20 LOCK		
7	86092130	1	CART BASE ASM, SPOTTER		
8	86006590	2	SCREW, 10-32 X 1/2 PPHMS SS NP		
9	86228340	1	BASKET, CART		
10	86232530	1	CASTER, 2.5 DIA		
11	86010630	2	WASHER, 1/4 ID X 5/8 OD SS		
-	86000030	-	SPOTTER CART		ENTIRE ASM AS KIT

Suggested Spare Parts

REF	PART NO.	DESCRIPTION	SERIAL NO. FROM	NOTES:
1	86225110	SWITCH, DPST 250V 16(4) SPLASH		
2	86258440	VAC MOTOR, 120V 2ST LNP		
3	86225500	VAC MOTOR, 230V 2ST LNP		
4	86201110	PUMP, 110/120 60HZ FLOJET		
5	86201120	PUMP, 220/240V 50HZ FLOJET		
6	86135320	BRUSH SET, 120V VAC, WINDSOR		120V MOTOR ONLY
7	86135330	BRUSH SET, 230V VAC, WINDSOR		230V MOTOR ONLY

REF. NO.	MODEL: SERIAL #
1	N/A