

# OPL-ADVANTAGE

Automatic Dispensing System For Commercial Laundry Machines.

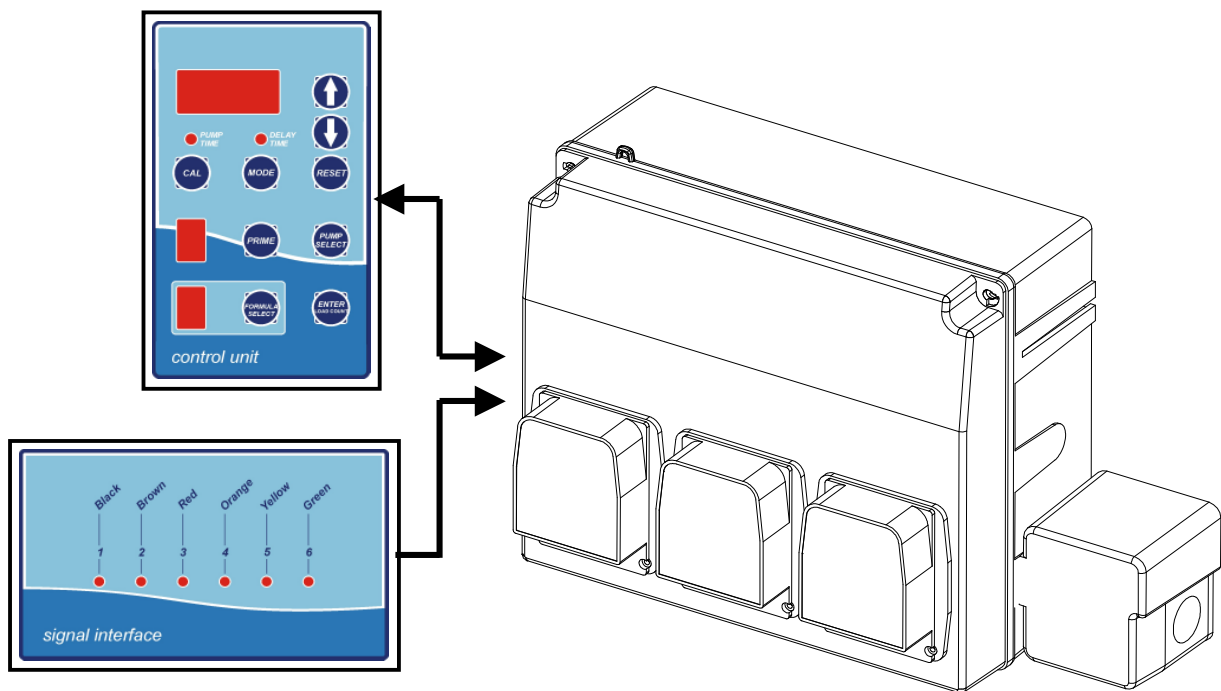

## Table of contents

1	Getting started.....	Page 2
2	Installation .....	Page 5
3	Working and Programming .....	Page 8
4	Accessories and Maintenance .....	Page 15
5	Troubleshooting .....	Page 15
6	Quick Reference .....	Page 16



## OPL-ADVANTAGE – OPL system

# 1 GETTING STARTED

## 1.1 Welcome

Thank you for purchasing this quality Seko product.

With the OPL-Advantage for commercial laundry machines, our company supplies a high-quality product suitable for all applications. Linear programming of the wash cycles along with simple program selection make the

OPL-Advantage the most user friendly choice. The OPL-Advantage allows up to 9 formulas to be programmed.



**Follow all warnings and precautions in this manual.**

## 1.2 What's in the box?

Before starting, verify the contents of the box:

- **OPL-ADVANTAGE** system without flushing manifold (pump unit, remote control and signal interface).
- Instruction manual.
- Mounting kit.
- Adhesive Velcro strip for securing the control console in place
- Drilling template.
- 1 Sekobril tube for Surfactants

## 1.3 Technical Features

### **Pump unit:**

- Accepts any power supply from 100VAC to 240VAC 50/60Hz
- Maximum consumption: 30 W (*100 W for the OPL Advantage High Volume*)
- Pump flow rate: 10 oz/min (*17/34/50/67 oz/min for the OPL Advantage High Volume*)
- Waterproof cabinet
- Alarm output (optional): Relay type contact normally closed 250V 8A max.

### **Signal Interface:**

- Output: 24VDC.
- Trigger signal voltage: from 20VAC to 230VAC
- Trigger signals: 6 and trigger 1 is also the drain counter
- Cable: phone type 8 contacts.
- Length cable: 23 ft.

### **Programmer/Program Selector**

- Power supply: 24VDC
- Cable: phone type 6 contacts.
- Length cable: 25 ft.
- 9 formula capability

## OPL-ADVANTAGE – OPL system

### 1.4 Description of the System

#### Description and function of keypad:

- 1) **KEY** ↑ Is used to increase programmed run and delay times or set the drain count in “Drain” mode. Hold down to scroll rapidly.
- 2) **KEY** ↓ Is used to decrease programmed run and delay times or to set drain count in “Drain” mode. Hold down to scroll rapidly.
- 3) **RESET KEY**: Restarts the system during a programming step.



**CAUTION!!! Reset does not erase all data from memory.**

- 4) **TIME MODE**: For scrolling to the desired feed and delay times. Also for designating Drain counts in Drain mode. (Pump time led will be blinking when setting feed times and delay time led will be blinking when setting delay times).
- 5) **CAL (Calibrate) KEY**: Allows product volumes to be set by calibration. Press this key to start pump while measuring output. Press again to stop. This will set the pump for that volume in the selected formula.
- 6) **PUMP SELECT KEY**: Use this key to select the pump to be calibrated or programmed.
- 7) **PRIME KEY**: After selecting a pump, press this key to run for the programmed time.
- 8) **ENTER/LOAD COUNT KEY**:
  - a) To check load counts when in RUN MODE press this key to show load count for the formula displayed.
  - b) To skip lockout time in RUN MODE.
  - c) To reset to level one.
  - d) To select “**END**” Pump. This is necessary for correct programming.
- 9) **FORMULA SELECT KEY**: This key scrolls through formula numbers to program, edit or run.

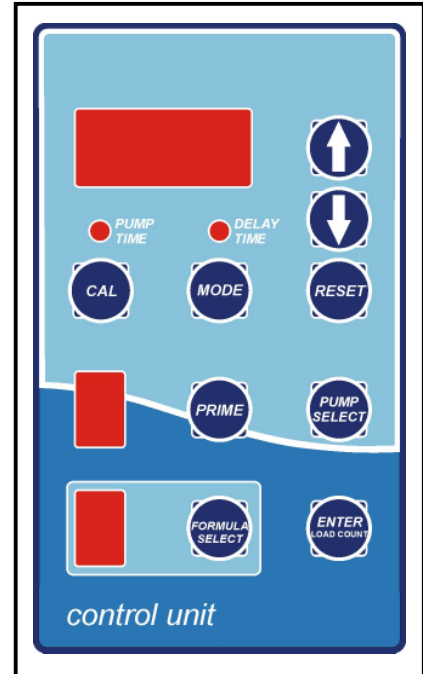

#### Description of displays

The 3-digit display shows:

- Pump run and delay times
- Drain counts in DRAIN mode
- Load counts

The PUMP display shows:

- The PUMP/TRIGGER number; LEVEL 1 or LEVEL 2 and F “Flush mode”.

The formula display shows:

- The number of formula, r “relay mode” and A for programming

## OPL-ADVANTAGE – OPL system

### 1.5 Warnings



Read this manual carefully before proceeding with the installation and starting up the OPL ADVANTAGE system.



The dosing unit should be connected to the power supply by means of a single-pole breaker having an opening distance equal to or greater than 3 mm.



Check the model of the equipment purchased for the reference information contained in this manual for installing, setting and programming it.



For all connections, refer to the diagram of the control circuit contained in this manual.



**CAUTION:** Always follow the appropriate safety procedures, including the use of suitable means for protecting the eyes, face, hands and clothing.



**CAUTION:** Always disconnect the equipment from the power supply before carrying out the installation or any maintenance work on it.



Seko is working constantly to improve all its products, and reserves the right to make changes at any time without prior notice.



Failure to comply with the instructions contained in this manual could cause damage to property or personal injury, prejudice proper functioning of the equipment or damage it.

### 1.6 Material required for installation

- Electrical cable for connections.
- Different tie-wraps to secure tubing and cables.
- PVC hose 7/16" OD x 5/16" ID (for pick-up and delivery)



Other installation material is also available (see chapter 5, Maintenance and Accessories).

## OPL-ADVANTAGE – OPL system

### 2 Installation



**CAUTION:** Do not install the equipment close to sources of heat.

#### 2.1 Wall mounting

- Use the drilling template to drill the holes for the anchors.
- It is advisable to install the system at a height of about 5 ft from the ground, and in any case in the vicinity of the product containers.
- Mount the brackets to the wall with the supplied ¼" anchor bolts (Picture 1).
- After securing the brackets in place, hang the OPL-ADVANTAGE System from them, as shown in the picture 2.

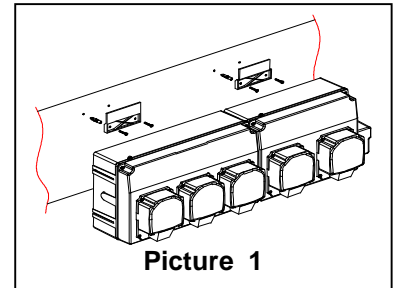

**Take care to secure the brackets to the wall correctly; Any errors in centering them would make it difficult to mount the OPL-ADVANTAGE**



**If the surface of the wall is not perfectly flat, making it difficult to mount the brackets, it is possible to secure the box directly to the wall by drilling through the breaking lines inside each box and mount the box to the wall using the supplied ¼' anchor bolts. To maintain the IP protection degree, it is advisable to apply silicone to the screws inside the box.**

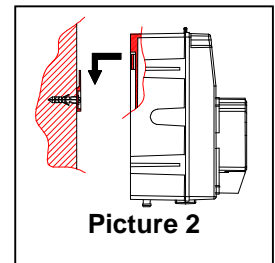

#### 2.2 Electrical connections



**CAUTION:** Always disconnect the OPL-ADVANTAGE System and the laundry machine from the power supply before making any connections.



**All the wiring connections to the OPL-ADVANTAGE System should be checked using a multimeter. Incorrect connections could seriously damage the unit and invalidate the warranty. Refer to the wiring diagram contained in this manual for all signaling and power-supply connections.**

##### 2.2.1 Power supply

Insert the cable through the PG7 conduit on the left of pump unit after connects the cable on the circuit board as shows the picture 3:

With the OPL ADVANTAGE, there is no need to select a voltage for power supply. The circuit board, (located on the left side when facing the cabinet) will automatically detect and accept any voltage from 100VAC to 240VAC. This is known as **SEKO's AUTOMATIC SWITCHING** feature.

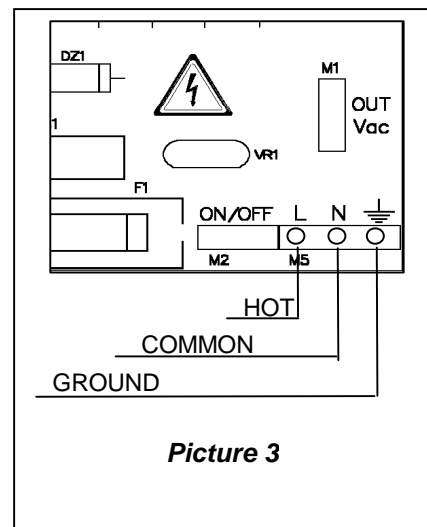

## OPL-ADVANTAGE – OPL system

### 2.2.2 How to connect the signal interface.

The signal interface unit may be placed inside or outside of the laundry machine as you determine to be suitable.

To fix the signal interface use the dual lock mounting strips. (Output is 24 Volt DC by means of a single RJ45, telephone type cable to connect to the OPL Advantage).

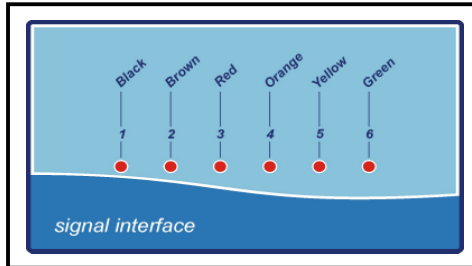

Picture 4

The signal interface has twelve 20" wires which connect to the laundry machine trigger signal source. To connect the signal interface to the OPL Advantage, you need to use the phone type cable with 8 contacts..

(RJ-45 cable) Wires are color coded to correspond to the pumps as follows:

Pump	Wire color	Common
1	Black	Black-COM
2	Brown	Brown-COM
3	Red	Red-COM
4	Orange	Orange-COM
5	Yellow	Yellow-COM
6	Green	Green-COM



All the trigger signal have a filter of 5 seconds.



If you want use just one common, connect together the wires marked "COM" to the common of the laundry machine.



If you want use the drain counter, you need to connect the drain valve to Pump 1 (Black-Black COM wire) of the signal interface.



If the laundry machine has residual tension on the signal, please open the Sim's box and move the jumper as show the picture below:

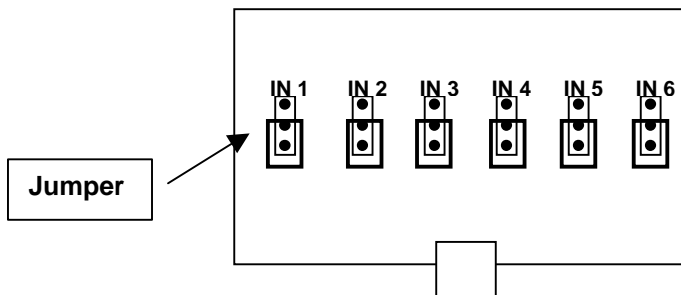

Picture 5

## OPL-ADVANTAGE – OPL system

### 2.2.3 How to connect the remote control

Mount the control unit in an easily accessible location with the dual lock mounting strips.

1. Connect the remote control to the OPL Advantage with the standard phone cable (6 contacts) into the terminal marked "CONSOLE" on the circuit board of pump unit. (To program the OPL Advantage see page 9).

### 2.3 Selection of the flow rate for the pumps (mod. OPL Advantage High volume only)

In order to optimize the dosing function, on the OPL Advantage model High volume it is possible to select the speed of the motors and therefore the flow rate of the pumps. (Picture 6)

- On OPL Advantage H is possible to select:

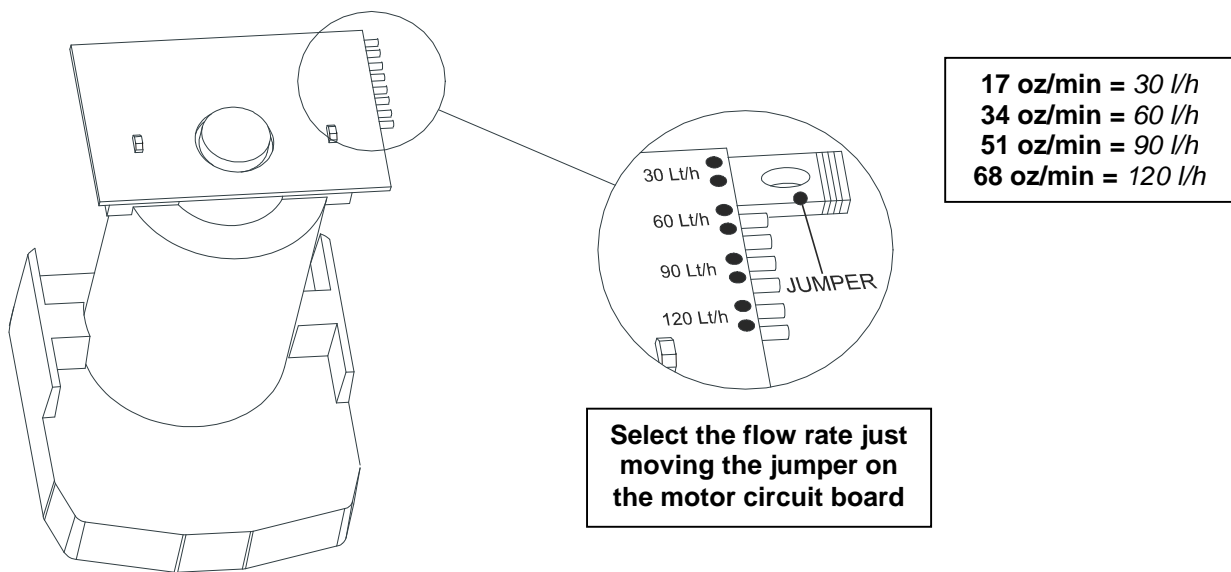

Picture 6

- ➔ The OPL Advantage High Volume systems are factory set with 34 oz/min of flow rate.



---

## OPL-ADVANTAGE – OPL system

### 3 WORKING AND PROGRAMMING

#### 3.1 Operating modes

##### 3.1.1 Normal

The system will accept up to 9 selectable formulas, with each pump having individual run and delay times. Pumps are triggered to run from signals from the washer. Run and delay times are controlled by the electronics of the OPL-Advantage. Laundry personnel select the appropriate wash formula using the "FORMULA SELECT" key before starting the wash cycle. The initial signal to pumps 1 - 6 will run "level" 1. If these pumps are signaled a second time **in the same formula**, "level" 2 will run. (Assuming the signal lockout time, if programmed, has expired) Pumps 1 – 6 will accept further signals with a change of formula number, a signal to the Load Count Pump or by pressing the RESET button.

**\*\*\* NOTE: SEKO's Automatic Switching Feature will allow programming of 3 or more pumps to run simultaneously without loss of output)**

"Two Level" programming is possible with Pumps 1 to 6. If no level 2 is needed, it can be bypassed by not programming a pump run time for that level. The second signal will run the programmed second level.

##### 3.1.2 Flushing

The Flush manifold activates with any pump signal, and then continues with a timed after flush, as programmed, when the pump stops. The optional flow switch senses contact from the flushing action. (If a flow switch is not used, a yellow wire jumper, located in the lower right area of the board, will be in place). A "flush error" will occur when there is no contact (either by the switch or jumper) at the terminals while the manifold runs. The letter "F" blinking in the pump window and the buzzer sounding indicates a flush error. Pump "F" is programmed only when a flush manifold is used.

##### 3.1.3 Relay

Laundry machines that have microprocessor controllers allow the OPL-Advantage to be programmed in relay mode. In this mode, pumps run whenever a signal is present. Formulas are selected at the keypad of the washer. The OPL-Advantage controller displays an "r" in the formula number window. Relay mode is set by entering the access code, choosing formula "r" in the "FORMULA SELECT" window. To designate a load count pump refer to the Load Count section of this manual.

##### 3.1.4 Drain

The capability of programming based on Drain function adds to the versatility of the OPL-Advantage. It provides a user friendly signal interface capability to machines where customary supply signals are not present and/or in cases where the washer's supply signals are inoperative or faulty. Drain Mode requires only one signal source.

(Complete instructions for drain mode: see page 11)



## OPL-ADVANTAGE – OPL system

### 3.2 Programming

#### NOTE: Read thoroughly before programming

- To program, prime, or clear memory enter the **access code**.
- **Pump “F”** is used to program the flush manifold.
- **Formula “A”** is used for storing the access code, setting signal lock-out time, system lockout time, pump 7 & 8 enable/disable, delay units, drain mode, and pump level enable/disable.
- **Formula “r”** is displayed for relay mode.
- A **“load count pump” must be set** for proper system operation.
- **Pumps 1 - 6** accepts two different injection amounts (Level 1 and Level 2) during a formula.  
Pump numbers and their corresponding second level are as follows:  
Pump/Second Level      1/A; 2/B; 3/C; 4/D; 5/E; 6/0





**EVERY TIME YOU CHANGE A PARAMETER PRESS RESET KEY.**

#### 3.2.1 Access code

To enter the system without an access code:

- 1) Press  key and then **ENTER**;

To enter the system with an access code::

- 1) Select the correct code with   keys (default is 000) and after press **ENTER**;
- 2) The 3-digit display will blink for 3 seconds: 



- 3) The **pump time led** will begin blinking;
- 4) The number 1 will appear in the PUMP SELECT and FORMULA SELECT displays;

#### 3.2.2 Clearing the memory

- 1) Enter access code (see par.3.2.1);
- 2) Hold simultaneously - **MODE** and **FORMULA SELECT** for 3 seconds;
- 3) All the led will be off and the 3-digit display appears: 

CLr displays for 10 seconds and then the system returns to normal operation.

#### 3.2.3 Change access code

- 1) Enter access code (see par. 3.2.1);
- 2) Select **PUMP “1” and FORMULA “A”**;
- 3) Select a new code with   and then press **ENTER**;
- 4) The 3-digit display will blink for 3 seconds to confirm the change.

#### 3.2.4 Programming Pump Run Times/Priming

- 1) Enter access code (see par. 3.2.1);
- 2) The pump time LED should be flashing. If the delay time LED is flashing, scroll to pump time with the MODE key.
- 3) Using the PUMP SELECT button choose the pump. Then do one of the following:
- 4) If pump run times haven't been programmed, press “CAL” to manually start and stop the pump. Press **ENTER** to set the time after each pump is calibrated. (Pump run times can also be set by scrolling the arrow keys up or down to the desired run time in seconds and then pressing **ENTER**).
- 5) If pump run times have been programmed, press “PRIME” to activate the set run time for the pump. This will also confirm the accuracy of the programmed run time (volume). Press “RESET” to stop the pumps during the prime function.



**Example: If in formula 1 we have programmed a time for pump 1 of 20 seconds, with the PRIME key you'll have a priming maximum of 20 seconds.**



## OPL-ADVANTAGE – OPL system

### 3.2.5 Selecting delay time units:

Pump delay times can be set in one second increments for 0 - 255 seconds, or one minute increments for 0 – 99 minutes. Determine the longest delay time required for the system, and select the appropriate delay time units.

- 1) Enter access code (see par. 3.2.1);
- 2) Select **PUMP “3” and FORMULA “A”**;
- 3) Press  $\uparrow$  to select 001(seconds) or 060(minutes) on the display:

 Seconds

 Minutes

- 4) Press **ENTER** to confirm.
- 5) Press **RESET**.

### 3.2.6 Programming pump delay times:

- 1) Enter access code (see par. 3.2.1);
- 2) Ensure that the delay time LED is flashing. If not, press MODE to select delay time.
- 3) The 3-digit display shows 0 0 0 if delay units are seconds or - 0 0 if delay units are minutes;

 Seconds

 Minutes

- 4) Use the SELECT buttons to choose desired pump and formula.
- 5) Use  $\uparrow$ / $\downarrow$  to set the delay time;
- 6) Press **ENTER** to confirm.
- 7) Press **RESET**

### 3.2.7 Programming flush:

If a Flush Manifold is being used, you need to program the time. To perform the following procedure:

- 1) Enter access code (see par. 3.2.1);
- 2) Dispense an ounce of chemical into the manifold. (Use a colored product)
- 3) Choose pump F and the formula number with the pump and formula SELECT buttons.
- 4) The pump time LED should be flashing. If not press MODE to choose pump time.
- 5) Press CAL. The flush solenoid will open and the 3-digit display will start counting the flush time.
- 6) Once the product is cleared from the line, press CAL again to stop the flush. The display will stop counting and the display will indicate the time needed to flush the line.
- 7) Press ENTER and the display will flash and the flush time is set.
- 8) Repeat these steps for each formula - - -

OR

- 9) You can manually program the flush time by selecting pump F and the desired formula. Set the flush time with the  $\uparrow$ / $\downarrow$  KEYS.



## OPL-ADVANTAGE – OPL system

### 3.2.8 Load count

The load count pump of the OPL-ADVANTAGE performs a number of important functions.

- 10) Counts total loads for each formula.
- 11) Terminates programmed lockout times (see par. 3.1.8).
- 12) Activates the system reset timer
- 13) Resets “levels” on pumps 1 – 6. NOTE: The pump used for load counts accepts only 1 wash level.

Select the last pump to receive a signal during any wash formula. The pump designated for load count **must** receive a signal at the end of the formula. A signal should be received even if the pump will not dispense chemical for the selected formula.

### 3.2.9 Setting the load count pump:

- 1) Enter access code (see par. 3.2.1).
- 2) Press ENTER.
- 3) The pump time and delay time LED's will be off and the current load count pump will be briefly displayed in the pump window.
- 4) Use PUMP SELECT key for selecting the load count pump **number**. The display flashes during selection of the desired load count pump.
- 5) When the pump time LED returns (in 3 seconds) the pump number was accepted



**The END pump is the same for all formulas.**



**Note in DRAIN mode the END PUMP is PUMP 2 by default.**

### 3.2.10 Displaying the load count

Access code is not required to display load counts.

#### Normal mode

- 1) Press ENTER; The load count will be shown on the 3-digit window for the formula displayed; the single digit display located directly below the “CAL” key shows the END PUMP

To see the statistic for each formula and pump, perform the following procedure:

- 1) Formula: Press **FORMULA SELECT** to select the formula.
- 2) Press **PUMP SELECT** to select the pump.
- 3) If you set **Formula 0**, the 3-digit display reveals the total loads count for all formulas.
- 4) Clear load counts by pressing  $\downarrow$  while the count is displayed until the 3-digit display shows 000.

#### Drain mode

The programming procedure is the following:

- 1) Repeat the procedure to enter in DRAIN mode. (See par. 3.2.11 below)
- 2) Use FORMULA SELECT to display desired formula.
- 3) Press ENTER. The load count will be shown on the 3-digit window for the formula displayed; The END PUMP is displayed in the window directly below the “CAL” key.
- 4) After 5 seconds, the display flashes and returns to its previous appearance.
- 5) Clear load counts by pressing  $\downarrow$  while the count is displayed until the 3-digit display shows 000. Repeat these steps for all formulas.

## OPL-ADVANTAGE – OPL system

### 3.2.11 Enabling or disabling drain mode:

- 1) Enter access code (see par. 3.2.1);
- 2) Select **PUMP “5” and FORMULA “A”**;
- 3) Use  $\uparrow$  to select 000 “Disable” or 001 “Enable”.



Disable



Enable

- 4) Press **ENTER**;
- 5) The display flashes briefly indicating that enable/disable has been set.
- 6) Press **RESET**.
- 7) The display will show: 

### 3.2.12 Assigning drain numbers:

The programming procedure is the following:

- 1) Enter access code (see par. 3.2.1);
- 2) Press **MODE** until **pump time** and **delay time** led are simultaneously flashing.
- 3) Select the formula & pump.
- 4) Use  $\uparrow$ / $\downarrow$  to select the drain number (up to a maximum of 15);
- 5) Press **ENTER**;
- 6) The display will be flashing briefly to indicate that the drain number is set.
- 7) Repeat the same operation for all formulas and pumps used.
- 8) Press **RESET**.

### 3.2.13 Inverting drain mode signal:

The drain solenoid valve can be set as NO (normally open) or NC (normally closed).

The programming procedure is the following:

- 1) Enter access code (see par. 3.2.1);
- 2) Select **PUMP “6” and FORMULA “A”**;
- 3) Use  $\uparrow$  to select 000 “NC” or 001 “NO”



NC - Normal



NO - Inverted

- 4) Press **ENTER**;
- 5) The display will be flashing briefly to indicate that the new status has been accepted.
- 6) Press **RESET**.

## OPL-ADVANTAGE – OPL system

### 3.2.14 Set the lock-out time

The lockout feature provides the option of preventing unwanted injections when supply signals are received more than once in a wash formula. (Not recommended in drain mode).

The lockout available can be set for 0 – 75 minutes commencing when a pump stops. Additional signals for that pump are ignored for the set lock-out time. If the load count pump receives a signal during the lock-out period, the lock-out will terminate and prepare to accept the next formula.



**Example: If you set a 1 minute lock-out time, after the end of dosing of one pump, the OPL-ADVANTAGE will ignore the activation of the same signal for 1 minute.**

The programming procedure is the following:

- 1) Enter access code (see par. 3.2.1);
- 2) Select **PUMP "2" and FORMULA "A"**;
- 3) Use  $\uparrow\downarrow$  to set the time.
- 4) Press **ENTER**;
- 5) The display will be flashing briefly to indicate that the new status has been accepted.
- 6) Press **RESET**.



**In a lock-out is used in drain mode we suggest a lock-out time longer than the sum of the dosing and the delay time of the pump.**

### 3.2.15 Level enable/disable:

In normal operation, choose this option to disable the second level injection. The pumps will accept signals and run as normal with any future signals from the washer. (If the pump is not in a lockout time) In situations where the load count signal is skipped, either from operator error or machine malfunction, disabling levels can prevent a missed injection. This feature should be used in normal operation mode only.

The programming procedure is the following:

- 1) Enter access code (see par. 3.2.1);
- 2) Select **PUMP "7" and FORMULA "A"**;
- 3) Use  $\uparrow$  to select 000 "**Level enable**" or 001 "**Level disable**"



Enable



Disable

- 4) Press **ENTER**;
- 5) The display will be flash briefly indicating the enable/disable status is set.
- 6) Press **RESET**.

## OPL-ADVANTAGE – OPL system

### 3.2.16 Set reset timer

Use this feature when extra or “stray” signals are present during the final rinse or extract. This will allow for delaying the reset for up to 75 minutes from the time the load count pump starts.

In the normal mode the reset time starts when the end pump goes on.

In the drain mode the reset time starts when the end pump stops.

When the reset timer activates, it resets the lock-out, the levels and the drain counter.

The programming procedure is the following:

- 1) Enter access code (see par. 3.2.1);
- 2) Select **PUMP “8” and FORMULA “A”**;
- 3) Use  $\uparrow\downarrow$  to select the time.
- 4) Press **ENTER**;
- 5) The display will briefly flash indicating that the new reset status is set.
- 6) Press **RESET**.

### 3.2.17 Formula enable/disable:

This feature allows the display of only those formula numbers you want visible to the operators. This prevents the operator from inadvertently choosing an inactive formula. With a new dispenser or after clearing memory all formula numbers are visible by default.

The programming procedure is the following:

- 1) Enter access code (see par. 3.2.1);
- 2) Select **PUMP “F”**; The delay time led should be flashing. If not, press MODE to select delay time.
- 3) Select the formula to be disabled or enabled.
- 4) Use  $\uparrow$  to select 000 “**Enable formula**” or 001 “**Disable formula**”



Enable



Disable

- 5) Press **ENTER**;
- 6) The display will briefly flash indicating that enable or disable has been set.
- 7) Press **RESET**.



## OPL-ADVANTAGE – OPL system

# 4 MAINTENANCE AND ACCESSORIES

## 4.1 Maintenance

**CAUTION: Before servicing, always disconnect the power supply and close the water delivery valve.**  
Scheduled maintenance of the OPL ADVANTAGE unit includes the following:

- Regular replacement of the peristaltic tube (every year at least) or whenever required in the event of chemical aggression.
- Cleaning of the filter of the solenoid valve. (If applicable)
- Cleaning of the bottom filters of the suction devices.



**In order to control product buildup, water can be primed through the pumps and tubing as a scheduled preventive maintenance measure or as needed.**

### 4.1.2 Replacement of squeeze tubing

- Remove the face plate from the pump
- Remove the squeeze tube without disconnecting it from the connecting tubes in order to avoid any leak of product;
- Install the new tube into the pump;
- Replace the face plate;
- Carefully remove the tubes from the old tube and connect them to the new tube.
- Prime the pump and resume normal operation.

## 4.2 Accessories

Seko can supply a complete range of accessories for making the installation operations easier.

Wall mounting kit for flush kit:..... code 9900106481

This is used to secure the flush kit to a wall in a vertical position, if required, to facilitate drainage of the liquids. The kit includes 2 - mounting brackets, 2 - ¼" anchors and 20 ft PVC Hose 7/16" OD x 5/16" ID. 300 ft Roll PVC 7/16" OD x 5/16" ID ..... code 9900090090

# 5 Trouble-shooting guide

## 5.1 One or more pumps are not working:

If one or more pumps fail to deliver products as programmed during normal operation, check the following:

- Make sure that the pumps are correctly connected to the inputs: PUMP 1 to 6 on the circuit board.
- Make sure that the signal interface is correctly connected.

## 5.2 The pumps are running but the product is not being metered

Check the pick-up tube for any crimps or clogging.

Check the foot valves for clogging.

Check the squeeze tubing for pinholes or excessive wear

## 5.3 Solenoid valve

If the solenoid valve does not work, check the following:

- Make sure it is correctly connected to the circuit in the SOL position.
- Make sure that there is a proper flow of incoming water (valve open).
- Make sure that automatic opening has been enabled.

## 5.4 After replacing an empty product container, the level alarm of the system persists:

- This may happen with products that have a high viscosity. Wait for a few seconds for the float of the suction device to return to its normal position.

## 6 Basic Programming - Quick Reference

### 1. Entering The System (PROGRAM MODE)

To Initially enter the system without the access code press  $\uparrow$  and then **ENTER**. (if you choose to set your own access code, after entering the system, select **PUMP “1”** and **FORMULA “A”**, scroll to the new code with  $\uparrow$   $\downarrow$  then **ENTER**) The three digit display will blink **“ACC”** for three seconds and the pump time LED will begin blinking. **The number 1 appears in the PUMP SELECT and FORMULA SELECT displays.**

### 2. Programming Pump Run Times, Delay Times and Priming

#### TO PROGRAM PUMP RUN TIMES

Enter the access code – The PUMP TIME LED should be flashing. Use the PUMP SELECT key and the FORMULA SELECT key to choose the pump and formula number to be programmed.

Program the pump run time by one of the following two methods:

**METHOD 1** - While measuring the output, press **“CAL”** to start the pump.

When the desired amount of product is dispensed, press **“CAL”** again to stop the pump. The dosing time will be displayed on the three digit LED. **Press ENTER to lock in the time.**

**METHOD 2** – Scroll to the desired dosing time with  $\uparrow$   $\downarrow$ . **Press ENTER.**

Repeat these steps for each pump in each formula to be programmed.

#### TO PROGRAM PUMP DELAY TIME

Enter the access code. Toggle to the DELAY TIME LED with **“MODE”** key. Choose the formula and pump with the PUMP SELECT and FORMULA SELECT keys. Scroll directly to the desired delay time up to 255 seconds. **Press ENTER.** (NOTE: Delay Time units can be changed from seconds to minutes by selecting **PUMP “3”** and **FORMULA “A”** and using the  $\uparrow$  key to select 001 (seconds) or 060 (minutes).

#### PRIMING

Enter the access code. Use the FORMULA SELECT and PUMP SELECT keys to select the pump to be primed. Press prime and the selected pump will run for the length of time programmed for that formula.

### 3. Programming Flush

Enter the access code. Using the PUMP SELECT key and the FORMULA SELECT key choose **PUMP “F”** and the desired formula number. The Pump time LED should be flashing. Press **“CAL”** and the flush solenoid will open and the 3-digit display will start counting the flush time. Press **“CAL”** again to end the flush time. **PRESS ENTER.** The  $\uparrow$   $\downarrow$  can also be used to scroll directly to a desired flush time. **Repeat for each formula.** During normal operation the solenoid will activate with any pump signal received in that formula and continue with the timed after flush when the pump stops.

### 4. Setting The Load Count Pump

A **“load count pump”** must be set for proper system operation as it performs a number of important functions. It terminates lockout times if used. It resets “levels” on pumps 1 – 6 if programmed. For further instructions on using these features please refer to the operation manual. This quick reference will focus it’s most common functions, i.e. 1.

Counting total loads for each formula and -

2. **“END”** pump function which resets the system’s timer preparing it for the next formula.

The “END” pump is the same for all formulas. Select the last pump that receives a signal on all programmed wash formulas. Consider if an external defeat switch is sometimes used and do not select that pump as the **Load Count/End** pump unless “Levels” have been disabled. Select the load count pump as follows:

1. Enter the access code. 2. Press ENTER.

*The pump time and delay time LED’s will be off. The current load count pump will be briefly displayed in the pump window*

3. Use the PUMP SELECT key for selecting the load count pump number. **Do Not** press enter.

*The display flashes during selection of the desired load count pump. In 3 seconds the pump time LED returns and the load count/end pump number was accepted.*

### 5. Relay Mode

(Dosing times are controlled directly from the laundry machine’s microprocessor and pumps run whenever a signal is present)

1. Enter access code 2. **Choose formula “r”** in the “FORMULA SELECT” window **then press “RESET”** once to set relay mode.

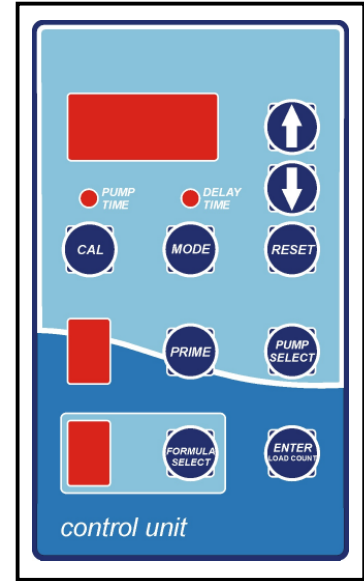





## OPL-ADVANTAGE – OPL system

### 6.1 Other Features and functions of the OPL Advantage – Quick Reference

**Drain Mode** - Allows programming based on Drain function. Drain mode requires only one signal Source.  
**See instruction manual pages 11 & 12**

**Lockout** - Provides the option of preventing unwanted injections if signals are received more than once during a formula. **See instruction manual page 13**

**Levels** - Pumps 1 to 6 will accept two different injection amounts (Level 1 and Level 2) during a formula. Pump numbers and their corresponding second level are as follows:

**1/A; 2/B; 3/C; 4/D; 5/E; 6/O;**

Level enable/disable allows you to disable the second level injection. This will offset situations where the load count pump is skipped, either from operator error or machine malfunction, preventing a missed injection. **See instruction manual page 13**

**Formula enable/disable** - This features allows you to display only those formulas you want visible to the operators. **See instruction manual page 14**

#### **PUMP/FORMULA - Programming Commands**

After entering the access code, enter these PUMP/FORMULA commands to program functions:

CHANGING ACCESS CODE	Pump 1 +	Formula A
SET SIGNAL LOCKOUT	Pump 2 +	Formula A
SELECT DELAY UNITS (Display: 001 for seconds; 060 for minutes)	Pump 3 +	Formula A
DRAIN MODE - enable/disable (Display: 001 enable; 000 disable)	Pump 5 +	Formula A
DRAIN MODE – inverting signal (Normally Open/Normally Closed)	Pump 6 +	Formula A
PUMP LEVELS – enable/disable (Display: 000 enable; 001 disable)	Pump 7 +	Formula A
SET RESET TIMER	Pump 8 +	Formula A
FLUSH MANIFOLD	Pump F +	Selected Formula Number
FORMULA - enable/disable (Display: 000 enable; 001 disable)	Pump F +	Toggle To Delay Mode LED Flashing

***NOTE: This quick reference will help you program most basic OPL applications. For any questions it is advised that you become familiar with the installation and programming portions of the complete instruction manual for the OPL Advantage.***



OPL-ADVANTAGE – OPL system

6.2 Pump Run-Time Output Chart – Quick Reference

10 oz Pump		16.7 oz Pump		33.3 oz Pump		50 oz Pump		66.7 oz Pump	
Formula Ounces	Run-Time Seconds	Formula Ounces	Run-Time Seconds	Formula Ounces	Run-Time Seconds	Formula Ounces	Run-Time Seconds	Formula Ounces	Run-Time Seconds
0.5	3	0.5	1.8	0.5	0.9	0.5	0.6	0.5	0.4
1	6	1	3.6	1	1.8	1	1.2	1	0.9
2	12	2	7.2	2	3.6	2	2.4	2	1.8
3	18	3	10.8	3	5.4	3	3.6	3	2.7
4	24	4	14.4	4	7.2	4	4.8	4	3.6
5	30	5	18.0	5	9.0	5	6.0	5	4.5
6	36	6	21.6	6	10.8	6	7.2	6	5.4
7	42	7	25.1	7	12.6	7	8.4	7	6.3
8	48	8	28.7	8	14.4	8	9.6	8	7.2
9	54	9	32.3	9	16.2	9	10.8	9	8.1
10	60	10	35.9	10	18.0	10	12.0	10	9.0
11	66	11	39.5	11	19.8	11	13.2	11	9.9
12	72	12	43.1	12	21.6	12	14.4	12	10.8
13	78	13	46.7	13	23.4	13	15.6	13	11.7
14	84	14	50.3	14	25.2	14	16.8	14	12.6
15	90	15	53.9	15	27.0	15	18.0	15	13.5
16	96	16	57.5	16	28.8	16	19.2	16	14.4
17	102	17	61.1	17	30.6	17	20.4	17	15.3
18	108	18	64.7	18	32.4	18	21.6	18	16.2
19	114	19	68.3	19	34.2	19	22.8	19	17.1
20	120	20	71.9	20	36.0	20	24.0	20	18.0
21	126	21	75.4	21	37.8	21	25.2	21	18.9
22	132	22	79.0	22	39.6	22	26.4	22	19.8
23	138	23	82.6	23	41.4	23	27.6	23	20.7
24	144	24	86.2	24	43.2	24	28.8	24	21.6
25	150	25	89.8	25	45.0	25	30.0	25	22.5
26	156	26	93.4	26	46.8	26	31.2	26	23.4
27	162	27	97.0	27	48.6	27	32.4	27	24.3
28	168	28	100.6	28	50.5	28	33.6	28	25.2
29	174	29	104.2	29	52.3	29	34.8	29	26.1
30	180	30	107.8	30	54.1	30	36.0	30	27.0
31	186	31	111.4	31	55.9	31	37.2	31	27.9
32	192	32	115.0	32	57.7	32	38.4	32	28.8
33	198	33	118.6	33	59.5	33	39.6	33	29.7
34	204	34	122.2	34	61.3	34	40.8	34	30.6
35	210	35	125.7	35	63.1	35	42.0	35	31.5
36	216	36	129.3	36	64.9	36	43.2	36	32.4
37	222	37	132.9	37	66.7	37	44.4	37	33.3
38	228	38	136.5	38	68.5	38	45.6	38	34.2
39	234	39	140.1	39	70.3	39	46.8	39	35.1
40	240	40	143.7	40	72.1	40	48.0	40	36.0
41	246	41	147.3	41	73.9	41	49.2	41	36.9
42	252	42	150.9	42	75.7	42	50.4	42	37.8
43	258	43	154.5	43	77.5	43	51.6	43	38.7
44	264	44	158.1	44	79.3	44	52.8	44	39.6
45	270	45	161.7	45	81.1	45	54.0	45	40.5
46	276	46	165.3	46	82.9	46	55.2	46	41.4
47	282	47	168.9	47	84.7	47	56.4	47	42.3
48	288	48	172.5	48	86.5	48	57.6	48	43.2
49	294	49	176.0	49	88.3	49	58.8	49	44.1
50	300	50	179.6	50	90.1	50	60.0	50	45.0

*This chart can be used to program formulas prior to being at the installation site or for programming approximate relay-mode pump run-times.*

*This chart is approximate and does not take into account different viscosities of products. Please use this as a starting point for calibration of products.*