

WAREPlus SERIES

Dosing Systems for Commercial Dishmachines

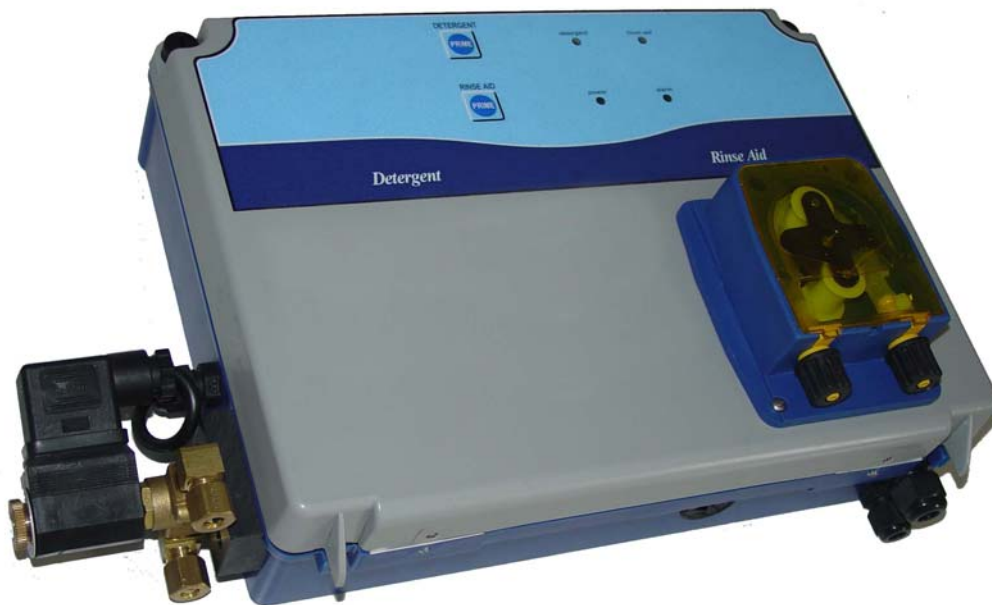

Contents

1	Getting started.....	Page 2
2	Installation.....	Page 3
3	Set-Up	Page 9
4	Priming and Delime Mode.....	Page 11
5	Probeless Mode.....	Page 12
6	Led display.....	Page 14
7	Maintenance & Accessories	Page 16
8	Troubleshooting	Page 16
9	Contact Us.....	Page 17

1.0 GETTING STARTED

1.1 WELCOME

Seko's **WAREPlus** has a new look and is simple to install, set up and use. The **WAREPlus** features microprocessor technology for accurate chemical dosing to commercial dish machines. Independent electronic circuit boards control product dispensing to the wash tank by use of a solenoid valve for dry detergent or a peristaltic pump for liquid detergent, rinse agent and sanitizer. Injection control is set with DIP switches and easy-to-adjust trimmers.

The **WAREPlus** operates in either probe or probeless mode to control detergent. **In Probe Mode**, detergent concentration is maintained by a conductivity probe inside the wash tank. The system's alarm feature, alerts the operator of empty product when a preset time is exceeded. **In Probeless Mode**, a timed dosage for initial charge and make up charge is set by taking signals from the fill and/or final rinse solenoids or, if available, the dish machine's rinse supply control circuit. An optional empty product alarm system is available for probeless operation.

Rinse aid dosing is controlled with a speed setting for the peristaltic pump.

We think you will find that installing, setting up and using the **WAREPlus** is the easiest, most intuitive dosing system available to your industry.



Please review this manual carefully. Pay particular attention to warnings and precautions. Always follow good safety procedures, including the use of proper clothing, eye and face protection.



Please be sure to read this manual and select operating mode before installation.

1.2 WHAT'S IN THE BOX?

Before you start, check that your box contains the following items:

- WAREPlus system
- Mounting kit
- Rinse aid kit
- Sanitizer kit¹
- Pressure Switch kit²
- Conductivity probe with connector
- Jumpers
- Poly outlet tube ¼" OD x 0.170 ID (6.6 ft) for rinse and sanitizer pump
- PVC tube ¼" OD x 0.170 ID (6.6 ft) for each pump

⁽¹⁾ Only on 3-pump models ⁽²⁾ Only on Pressure Switch models

1.3 TECHNICAL FEATURES

- Power supply: 100-240 Vac 50/60 Hz
- Consumption: 14 W
- Fuses: 200mA @ 250VAC, 5x20 type
- Detergent pump flow rate: 0.7 ... 4.2 oz/min @ 1.5psi
- Rinse aid pump flow rate: 0.1 ... 0.7 oz/min @ 45psi
- Sanitizer pump flow rate: 0.1 ... 0.7 oz/min @ 45psi
- Max. working conductivity: 10,000 micro siemens
- Water resistant
- Weight: 7.7 lbs
- Dimensions:

Version LL • LLL W 11.2" x D 4.3" x H 8.7"

Version DL • DLL W 14.2" x D 4.3" x H 8.7"

with pressure switch:

Version LL • LLL W 14.2" x D 4.3" x H 8.7"

Version DL • DLL W 17.2" x D 4.3" x H 8.7"

WAREPlus Series – Dishwasher systems

1.4 WARNINGS



Check pressure at the rinse injection point. Max-recommended pressure for the rinse pump is 45 psi.



Be sure pick-up tubes are placed in the proper product containers.



All electrical connections to the WAREPlus should first be checked with a meter. Application of incorrect voltage will permanently damage the unit and is not covered by warranty. Avoid wiring to any power source that has large fluctuations in voltage and/or is prone to surges. Refer to the wiring diagram in this manual for all power and signal connections.



Verify that the power supply is between 100 and 240 VAC.



CAUTION: The WAREPlus has high voltage connected to the transformer. Always disconnect power when servicing the unit.



CAUTION: During installation and electrical connections remove all power from the dishmachine.



Failure to follow these instructions may lead to personal injury, damage to the product or poor product performance.

1.5 MATERIAL REQUIRED DURING INSTALLATION

- Two poles cable: AWG 16 for the power supply.
- 1/4" OD copper tubing (for models with solenoid valve).

2 INSTALLATION

Mount the unit on a nearby wall (using suitable hardware) of the dishmachine. Try to keep the unit within 3.5 ft. from the final rinse line to avoid long tubing runs.

Check all applicable plumbing and electrical codes before proceeding with the installation. This will help to ensure that the system is installed in a safe manner. A wiring schematic of the dishmachine should be used as reference for making electrical connections. This is typically provided by the dishmachine manufacturer if it is not located inside the inspection cover of the machine's control box.



CAUTION: Do not mount the unit in the direct path of steam. This can short circuit and permanently damage the unit. Mounting the unit on the side, on the back, or over vents may cause thermal overload and damage or hinder the performance of the unit.

2.1 MOUNTING THE SYSTEM

- Apply the panel unit system with the brackets and screws supplied
- Determine a suitable location for the system
- Using the bracket as a template, mark and drill holes for bolting the system to the wall
- Insert the anchors in the holes
- Bolt the bracket in place (flat side against the wall with holes on bottom) with the hardware provided
- Open the Cabinet Front, by unscrewing the upper screws ¼ turn.

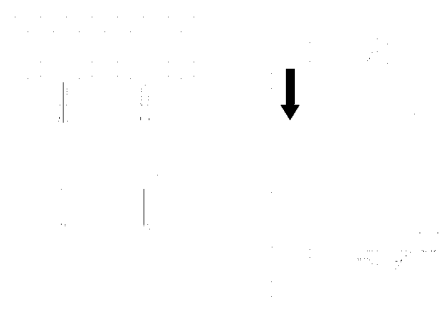

WAREPlus Series – Dishwasher systems

2.2 DESCRIPTION OF THE FRONT PANEL

Keys on the Front Panel

1. For the priming of the detergent hold the **DETERGENT PRIME**
2. For the priming of the rinse aid hold the **RINSE AID PRIME**
3. For the priming of the sanitizer hold the ***SANITIZER PRIME**

* Only on 3-pump models

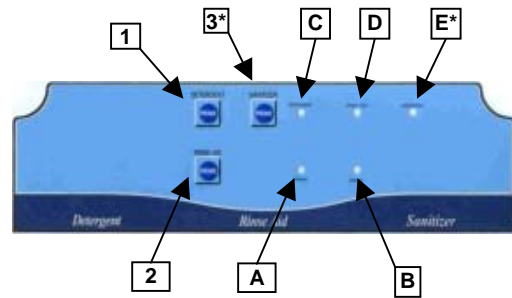

LEDs on the Front Panel

- A Power** Power supply LED, green, permanently on or flashing (see par. 6)
- B Alarm:** Alarm LED, red, permanently on or flashing (see par. 6)
- C Detergent:** Detergent pump LED, green, permanently on or flashing (see par. 6)
- D Rinse aid:** Rinse aid pump LED, green, permanently on or flashing (see par. 6)
- E *Sanitizer:** Sanitizer pump LED, green, permanently on or flashing (see par. 6)

* Only on 3-pump models

2.3 CIRCUIT DIAGRAM

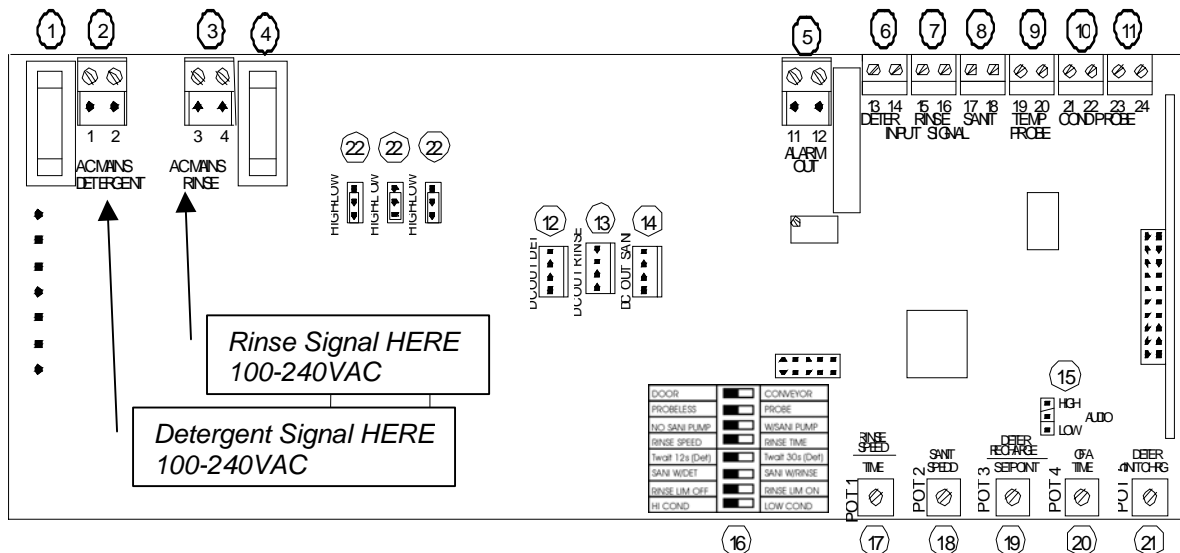

1	AC MAINS DETERGENT: Fuse for detergent supply
2	AC MAINS DETERGENT: Detergent signal terminal
3	AC MAINS RINSE: Rinse signal terminal
4	AC MAINS RINSE: Fuse for rinse supply
5	Alarm relay output
6	Detergent level probe input (optional)
7	Rinse aid level probe input (optional)
8	Sanitizer level probe input (optional)
9	Temperature probe input (optional)
10-11	Conductivity-measuring probe input

12	Detergent DC motor output
13	Rinse aid DC motor output
14	Sanitizer DC motor output
15	Buzzer volume selector
16	DIP-switch
17	Trimmer: Rinse aid pump speed or time
18	Trimmer: Sanitizer aid pump speed
19	Trimmer: conductivity-measuring probe set point/Detergent metering time for rinse operation
20	Trimmer OFA time
21	Trimmer: Detergent time for the first charge
22	Jumper to select High (from 150 to 265 VAC) or Low (from 20 to 265 VAC) input signal voltage

WAREPlus Series – Dishwasher systems

2.4 ELECTRICAL CONNECTIONS



CAUTION: The WAREPlus has high voltage connected to the transformer. Always disconnect power when servicing the unit.



All electrical connections to the WAREPlus system should first be verified with a meter. Application of incorrect voltage will permanently damage the unit and is not covered under warranty. Avoid wiring to any power source that has large fluctuations in voltage and/or is prone to surges. Refer to the wiring diagram in this manual for all power and signal connections. All wiring must conform to local electrical codes.

Power Supply from Detergent and Rinse Signals

Check the dishmachine for a **100 – 240 VAC** signal that is **only present during the wash cycle** and an **100 – 240 VAC** signal that is **only present during the rinse cycle**.

- Turn off the breaker to the dishmachine;
- Connect leads from the rinse-aid signal source to the rinse power input (**AC MAINS RINSE**) on the circuit board;
- Connect leads from the detergent signal source to the detergent input (**AC MAINS DETERGENT**) on the circuit board;

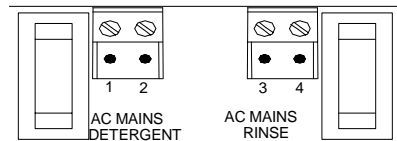

Power supply for the systems with Pressure Switch (PS)

Check the dishmachine for an **100 – 240 VAC** signal that is **present both during the wash and rinse cycle**.

- Turn off the breaker to the dishmachine;
- Connect leads from the signal source to the power input (white connector);

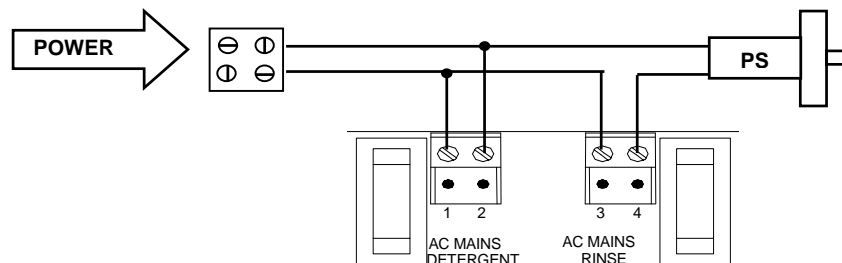

External Alarm (optional)

Connect the wires from the external alarm terminals to the **ALARM OUT** terminals on the circuit board (see picture on page 5).

Pick-Up with float switch (used with optional external alarm)

Connect the wires from the detergent level probe to the **DETER INPUT SIGNAL** on the circuit board. Connect the wires from the rinse aid level probe to the **RINSE INPUT SIGNAL** on the circuit board. Connect the wires from the sanitizer* level probe to the **SANIT INPUT SIGNAL** on the circuit board.

- Only on 3-pump models

******NOTE: 24 VAC CONVERSION KIT, ITEM # 9900106568 IS AVAILABLE FOR THE WAREPlus FOR INSTALLING ON MACHINES WITH 24 VAC DETERGENT AND RINSE CONTROL CIRCUITS**

PAY ATTENTION TO SET THE THREE JUMPERS FOR INPUT SIGNAL TO LOW (FROM 20 TO 265 VAC), OTHERWISE SYSTEM WILL NOT ACCEPT ANY SIGNAL FROM THE WASH MACHINE.

2.5 PLUMBING CONNECTIONS

Detergent Connections

2.5.1 Powder / Solid (Dry) Detergents

A bowl dispenser must be used to dispense dry detergent products. To install the dispenser follow the instructions enclosed with the dispenser and use the recommended water temperature and pressure. Make sure that the position of the detergent bowl is above the injection point.

- Cut a suitable length of ¼” copper tubing (not supplied) and connect it between one side of the **WAREPlus** solenoid valve and the water supply.
- Cut a suitable length of ¼” copper tubing (not supplied) and connect it between the other side of the **WAREPlus** solenoid valve and the bowl’s water inlet.
- Carefully tighten the compression nuts on the **WAREPlus** solenoid valve. Over tightening may cause water to leak from the solenoid valve.
- Tighten the connections to the water supply and the detergent dispenser.

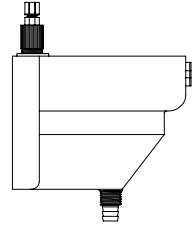

Maximum recommended water temperature 150° F (65 °C).



Water pressure: Minimum 15 psi - Maximum 40 psi



The solenoid valve of the WAREPlus accepts water flow in either direction

To install a powder detergent dispenser, proceed as follows:

- Find or make a 7/8” hole (detergent injection point) on the side of the wash tank above the water line, below the rack rails and as close as possible to directly above the conductivity probe and near the pump intake. Keep away from the corners. Fit the detergent union in the hole;
- Cut a suitable length of tubing (not supplied) and connect it between the detergent feed outlet and the injection fitting.

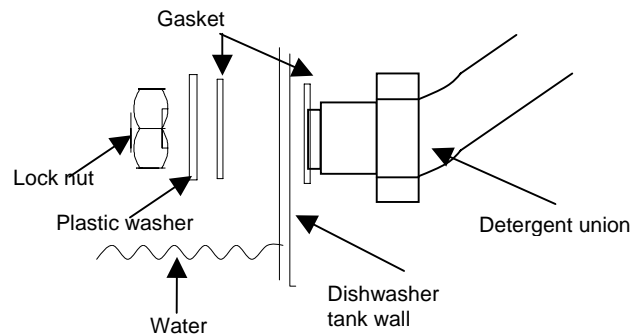

WAREPlus Series – Dishwasher systems

2.5.2 Liquid Detergent Connections

The following installation steps apply for detergent pump:

- **Pick-Up Tube** – To assemble the foot filter, Insert the 1/4" OD PVC tube to exit through the tapered side of the stainless steel weight. Push the filter through that end of the tube. Lock the tube by pushing the weight until it is flush with the top of the foot filter.
- **Outlet Tube** - Attach PVC tube to discharge side of detergent pump. Connect the other end to injection fitting.

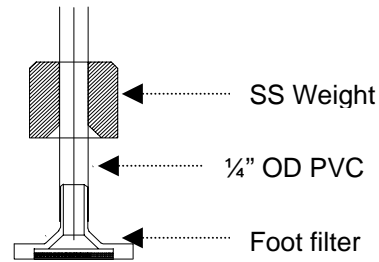

Always use the foot filter and make sure that it reaches the bottom of the tank. Periodically check and clean the filter of buildup and/or debris.

Delivery

- Connect the outlet hose to the discharge side of the detergent pump.
- Cut the necessary length of hose to reach the injection point and attach it to the injection fitting.
- Make a 7/8" diameter hole in the vertical side of the tank, just above the water level, apply the rubber washer as shown below, insert the threaded end of the injection fitting through the 7/8" opening and apply the other washer and secure with the large plastic nut.

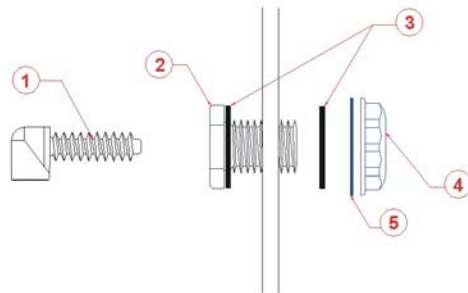

1	INJECTOR
2	CONNECTOR
3	RUBBER WASHER
4	FIXING NUT
5	PLASTIC GASKET

2.5.3 Rinse Plumbing

The following installation steps apply for the rinse pump:

- Install the 1/4" OD poly tube x 1/8" injection fitting into the side or bottom of the dish machine rinse line between the rinse solenoid valves and the rinse jets. If necessary, drill an 11/32" hole and tap to 1/8" NPT.
- Cut a suitable length of 1/4" OD poly tubing and connect to the discharge (right) side of the rinse pump and the injection fitting;
- Assemble the foot filter to insert in the rinse product container as described above for the detergent tube.
- Cut a suitable length of 1/4" OD PVC tubing and connect between the suction (left) side of the pump and the rinse product container.
- Hand-tighten the compression nuts on both the injection fitting and pump.

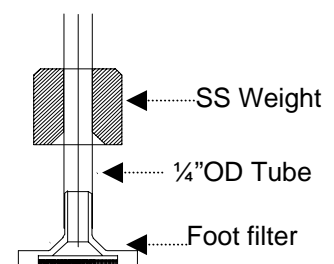

Always use the foot filter and make sure that it reaches the bottom of the tank. Periodically check and clean the filter of buildup and/or debris.

WAREPlus Series – Dishwasher systems

2.6 PROBE INSTALLATION AND CONNECTION

The probe senses the detergent concentration. Correct probe placement is critical for accurate detergent concentration control. Always use the new probe provided with the dispenser. The probe is to be in a location that is always immersed in the wash tank solution, has good flow of solution, and is close to the product entry point.

The probe's cable is 10 ft long.

- Install the probe in the wash tank below the water level. It should be away from incoming water supplies, near the circulating pump intake, and 3.14" to 4" from corners, heating elements, or the bottom of the tank;
- If an existing mounting hole cannot be located, use of a 7/8" hole saw or punch may be desired;
- Remove the probe retaining nut and insert probe with rubber gasket into hole from outside the dish machine tank
- Connect leads from the terminals on the probe to the probe terminals on the circuit board (see diagram below);
- Use the supplied cable for the probe connection. Avoid running the cable near high voltage AC lines.

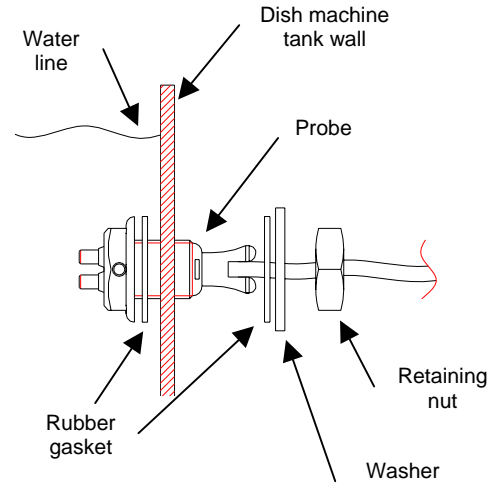

Locate the probe at least 8" from the detergent injection point!

CONNECTING THE CONDUCTIVITY PROBE

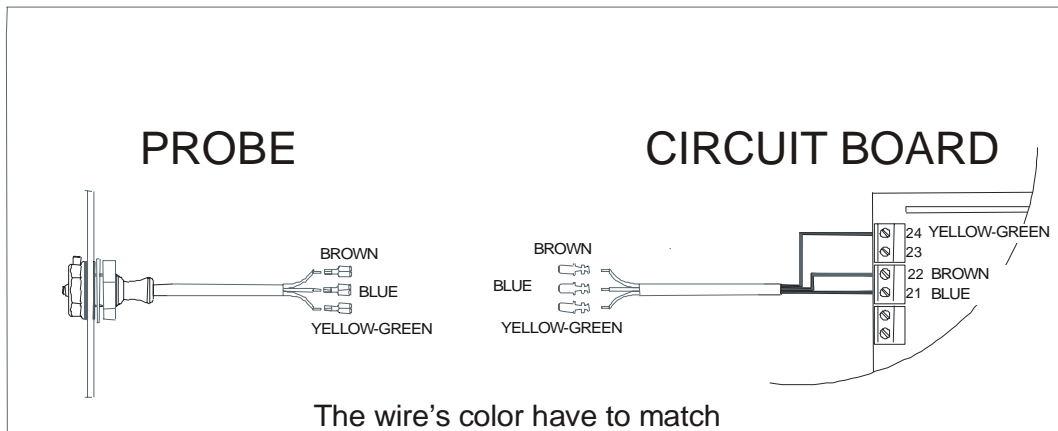









3. SET UP

3.1 DESCRIPTION OF THE DIP SWITCHES

• **Dip Switch 1** – Set to the “DOOR” position for door type machines. Set to the “CONVEYOR” position for conveyor machines

• **Dip Switch 2** – Set in the “PROBELESS” or “PROBE” position (detergent pump or solenoid valve will be controlled by time settings in the probeless mode or by automatically monitoring wash tank conductivity in probe mode).

• **Dip Switch 3**
 Left (OFF) system without Sanitizer pump
 Right (ON) system with Sanitizer pump

DOOR		CONVEYOR
PROBELESS		PROBE
NO SANI PUMP		W/SANI PUMP
RINSE SPEED		RINSE TIME
Twait 12s (Det)		Twait 30s (Det)
SANI W/DET		SANI W/RINSE
RINSE LIM OFF		RINSE LIM ON
HI COND		LOW COND

• **Dip Switch 4** – Set in the “RINSE SPEED” position (rinse aid pump will be managed by speed) Set in the in the “RINSE TIME” position (rinse aid pump will be managed by time)

• **Dip Switch 5** – Set in the “Twait 12s (Det)” position (in Probeless mode, conveyor machine wait time for detergent 12 seconds). Set in the “Twait 30s (Det)” position (in Probeless mode, conveyor machine wait time for detergent 12 seconds)

• **Dip Switch 6** – Set in the “SANI W/DET” position (sanitizer pump will work along with the detergent pump) Set in the in the “SANI W/RINSE” position (sanitizer pump will work along with the rinse aid pump)

• **Dip Switch 7** – Set in the “RINSE LIM ON” position for door type machines. (the rinse pump will stop when the rinse signal exceeds 30 seconds) Set in the in the “RINSE LIM OFF” position for conveyor machines (the rinse pump will run for as long as the AC MAINS RINSE signal remains active)

• **Dip Switch 8** –Set in the “HI COND” position (high conductivity). Set in the “LOW COND” position (low conductivity)

3.2 DETERGENT CONCENTRATION

The probe (conductivity cell) measures conductivity of the wash tank detergent solution. This conductivity is related to alkalinity (detergent strength). Chemical usage will vary as conditions in the wash tank constantly change. Among these conditions are temperature variation, changing water hardness, wash tank dilution rate, type and quantity of food soil and operator procedures. **POT3 (SETPOINT)** sets the detergent by turning clockwise to increase concentration.

When the detergent supply (**AC MAINS DETERGENT**) terminal receives an **100 – 240 VAC signal**, the conductivity probe senses detergent concentration in the wash tank; when concentration drops below the set point, the control automatically initiates the detergent feed and will stop when conductivity reaches 10% above set point.

The speed of the detergent pump automatically adjusts as follows:

- With concentration below 80% of the set point, the pump runs at maximum speed.
- With concentration between 80% and 90% of the set point, the pump runs at 50% of maximum speed.
- With concentration above 90% of the set point, the pump runs at 25% of its top speed.

An “out of product” alarm will automatically sound. If the detergent set point is not reached in a specific time period (**OFA**), and detergent feed will stop. To disable an alarm status remove the cause then restart the system.

WAREPlus Series – Dishwasher systems

3.3 TO ACHIEVE THE DESIRED PRODUCT CONCENTRATION FOLLOW THESE STEPS:

1. Start with the - **POT3 “SETPOINT”** - trimmer in the fully counter clockwise position.
2. Fill the tank with water and allow it to reach the recommended wash temperature.
3. Turn on the machine and the product will automatically dispense into the tank until the set point is reached.
4. Titrate and adjust trimmer clockwise to increase concentration as needed.

3.4 OFA (ALARM)

The OFA time can be set by the OFA TIME trimmer in a 1 second to 255 seconds range
To disable the OFA alarm, turn the OFA TIME trimmer completely counter-clockwise.

The alarm will sound when:

- The “out of product” alarm **OFA** is activated; this occurs when detergent concentration has not reached set point within the set time period. (“OFA TIME” trimmer can be set for 1 – 255 seconds)

Once the solenoid valve has started the system waits for the set OFA time. Once this time has elapsed, and the solenoid valve is still open, the alarm led on the screen will flash and the buzzer will sound at an intermittent slow rate. In this first OFA alarm phase the detergent pump will continue to run.

This alarm status will end if the set point is reached and the detergent pump stops. If an additional OFA set time elapses without the reaching the setpoint, the device will enter into the second phase of OFA alarm. In this phase the buzzer will sound faster, the alarm led will flash and the detergent pump will be stopped
IMPORTANT: Detergent feed will remain disabled until the machine is turned off and restarted.

3.5 RINSE OPERATION

POT1 sets the rinse pump speed. Turn clockwise to increase. The rinse pump will operate at the set speed whenever the rinse supply (**AC MAINS RINSE**) terminal on the circuit board receives an **100 – 240 VAC** signal.

3.6 DESCRIPTION AND SETTINGS FOR THE ALARM VOLUME JUMPERS

The buzzer volume can be set using jumper JP4 to HIGH or LOW volume, or it can be disabled.

- Select HIGH for loud volume.
- Select LOW for quiet volume.
- Remove the jumper to exclude the buzzer.

4 PRIMING AND DELIME MODE

4.1 PRIMING

- Holding the **DETERGENT PRIME** button, located on the front cover, will open the detergent solenoid valve or will allow the detergent pump to run at full speed. Power must be applied to the system to prime.
- Holding the **RINSE AID PRIME** button, located on the front cover, will allow the rinse pump to run at full speed. Power must be applied to the system to prime the pump.
- Holding the ***SANITIZER PRIME** button, located on the front cover, will allow the sanitizer pump to run at full speed. Power must be applied to the system to prime the pump.

* Only on 3-pump models

4.2 DELIME MODE

A stand-by status can be activated allowing the dishwasher to be delimed without having to turn off the WAREPlus. Enter DELIME mode by pushing **DETERGENT PRIME** and **RINSE PRIME** simultaneously. In DELIME mode, WAREPlus does not recognize any input signal, thereby disabling any type of dosing, even when the dishwasher is running.



When in DELIME mode, the DET LED flashes, the RIN LED flashes, the SAN LED flashes, and the ALARM LED flashes. The buzzer cannot sound, the alarm relay is deactivated, and the pumps are stopped.

To exit DELIME mode simply return to operating mode by pushing any button or restarting the machine.

5 PROBELESS MODE

NOTE: For best results, the Probeless mode should be used on machines with automatic fill.

Dip Switch #1 – Set for **Door Type** or **Conveyor Type** machine as below:

Left : to set **DOOR** machine

Right : to set **CONVEYOR** machine



Dip Switch #2 – Set in the **LEFT** position. (**Probeless Mode**)

Left : to set **PROBE** mode

Right : to set **PROBELESS** mode



POT5 (DETER INIT CHRГ) controls the **initial charge**, activated by the signal received at the AC MAINS - DETERGENT terminal. (1 – 255 seconds)

POT3 (DETER RECHARGE) regulates the **makeup charge**, activated by the signal received at the AC MAINS – RINSE. (1 – 30 seconds)

FOR CONVEYOR MACHINES

NOTE: A dedicated fill solenoid is needed for proper initial charge w/conveyor machines

Connect power from the FILL SOLENOID CIRCUIT to the “AC MAINS DETERGENT” terminal.

During the fill, the Detergent pump can be set to run from 1 – 255 seconds for the initial charge. Time is set with trimmer marked “**DETER INIT CHRГ**” (POT 5).

Connect power from the FINAL RINSE SOLENOID CIRCUIT to the AC MAINS RINSE terminal.

When the final rinse is activated, the Detergent pump can be set to run for 1 – 30 seconds with a 12 or 30 second “**Twait**” (DIPSWITCH #5) time before the pump will accept a new signal or resume feeding where a continuous signal is present. Time is set with trimmer marked “**DETER RECHARGE**” (POT3).

FOR DOOR MACHINES - (With automatic fill through rinse solenoid)

NOTE: Only one power connection is needed in this application. Connect power from the final rinse solenoid circuit to the AC MAINS RINSE terminal.

During the first 30 seconds of the fill, the detergent pump can be set to run for 0 – 30 seconds which is set by the trimmer marked “**DETER RECHARGE**” and then stop running until the filling cycle exceeds 30 seconds. At that point the detergent pump can be set to resume feeding for 1 to 255 seconds, which is set with POT5 marked “**DETER INIT CHRГ**”. During each rinse cycle during normal operation, a makeup charge of detergent will feed for 0 – 30 seconds as was set using POT3.

WAREPlus Series – Dishwasher systems

5.1 SANITIZER PUMP

DIP-switch 3 should be set as follows:

NO SANI PUMP	<input checked="" type="checkbox"/>	W/SANI PUMP
--------------	-------------------------------------	-------------

Left : No sani-pump

Right : With sani-pump

5.2 RINSE AID DOSING

The type of rinse aid dosing is selected using DIP-switch 4:

RINSE SPEED	<input checked="" type="checkbox"/>	RINSE TIME
-------------	-------------------------------------	------------

Left : to set **SPEED** for rinse aid dosing

Right : to set **TIME** for rinse aid dosing

The speed of the rinse pump can be adjusted by turning the SPEED/RINSE trimmer in a clockwise direction. It can be set from 7% to 100% of the pumps maximum speed.

5.3 SETTING RINSE SPEED

- Set DIP-switch 4 to RINSE SPEED
- The speed of the rinse pump can be adjusted by turning the RINSE SPEED trimmer in a clockwise direction. It can be set from 7% to 100% of the pumps maximum speed.

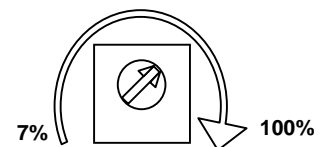

5.4 DOSING RINSE AID BY SETTING THE TIMER (RINSE TIME)

If the timer dosing mode is selected:

- Set DIP-switch 4 to RINSE TIME (RIGHT position).

The time of the rinse pump can be adjusted by turning the RINSE TIME trimmer in a clockwise direction. It can be set from 1 to 30 seconds.

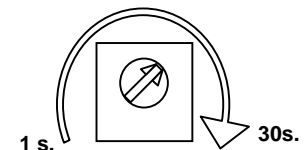

5.5 SANITIZER DOSING (only 3-pump models)

The sanitizer pump can be set to dose at the same time as the detergent or the rinse aid pump

The type of the sanitizer dosing is selected using **DIP-switch 6**:

SANI W/DET	<input checked="" type="checkbox"/>	SANI W/RINSE
------------	-------------------------------------	--------------

Left : the sanitizer pump is activated at the same time as the detergent pump.

Right : the sanitizer pump is activated at the same time as the rinse aid pump.

Install the sanitizer injection fitting to suit the mode chosen.

The speed and output of the sanitizer pump increases by turning the **SANIT SPEED (POT2)** trimmer in a clockwise direction.

5.6 RINSE DEFEAT

Dip switch 7 is used to select the rinse limit mode:

RINSE LIM OFF	<input checked="" type="checkbox"/>	RINSE LIM ON
---------------	-------------------------------------	--------------

Left The rinse pump will run at the set speed for as long as the **AC MAINS RINSE** signal remains active

Right This feature will stop the rinse pump after 30 seconds of continuous operation on dish machines that fill through the rinse valve. This prevents waste/overuse of rinse agent by shutting off the pump while the machine fills.

6 LED DISPLAY

A whole series of messages are indicated both during operation and in case of malfunction or alarm status, using the LEDs on the front panel of the WAREPlus.

LED DISPLAY DURING OPERATION

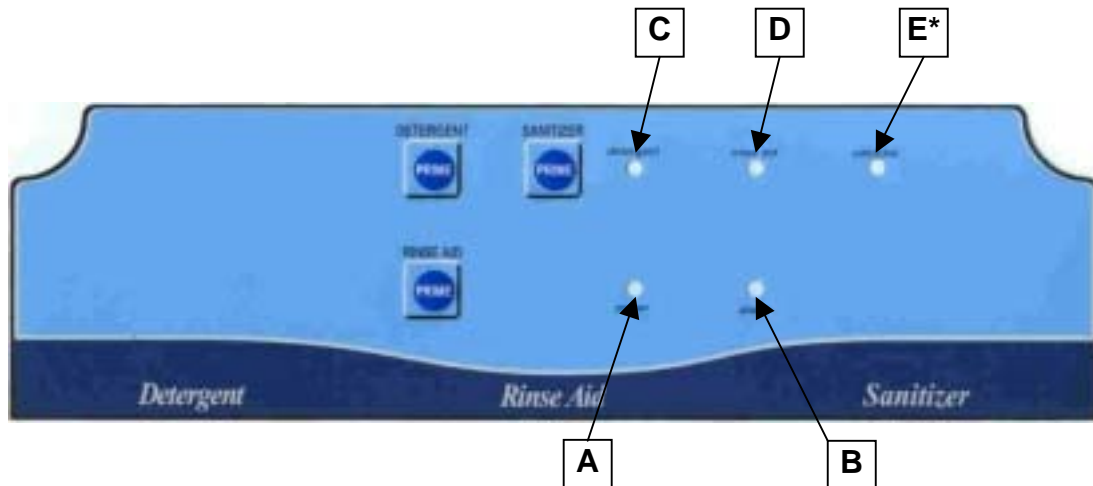

6.1.1 Stand-by display

The green LED A (**power**) stays on, this LED shows that the WAREPlus is switched on. **The buzzer and the relay output are de-activated.**

6.1.2 Display during priming

The green LED A (**power**) stays on, this LED shows that the WAREPlus is switched on. **The buzzer and the relay output are de-activated.**

- DETERGENT PUMP PRIMING: The green LED C (*detergent*) stays on
- RINSE AID PUMP PRIMING The green LED D (*rinse aid*) stays on
- *SANITIZER PUMP PRIMING: The green LED E (*sanitizer*) stays on

6.1.3 Display during dosing

The green LED A (**power**) stays on, this LED shows that the WAREPlus is switched on. **The buzzer and the relay output are de-activated.**

- DETERGENT PUMP DOSING The green LED C (*detergent*) stays on
- RINSE AID PUMP DOSING The green LED D (*rinse aid*) stays on
- *SANITIZER PUMP DOSING The green LED E (*sanitizer*) stays on

6.1.4 Display in DELIME mode

The green LED A (**power**) stays on, this LED shows that the WAREPlus is switched on. **The buzzer and the relay output are de-activated.**

- The red LED B (*alarm*) flashes
- The green LED C (*detergent*) flashes
- The green LED D (*rinse aid*) flashes
- *The green LED E (*sanitizer*) flashes

*Only in the 3 pump systems

WAREPlus Series – Dishwasher systems

6.2 ALARM LED DISPLAY

6.2.1 Motor fault alarm (contact your local dealer)

The green LED A (**power**) stays on, this LED shows that the WAREPlus is switched on.

The buzzer sounds for 1 second every 10 seconds.

- The red LED B (*alarm*) flashes
- The green LED C (*detergent*) flashes
- The green LED D (*rinse aid*) flashes
- *The green LED E (*sanitizer*) flashes

6.2.2 Over feed alarm OFA1: abnormal detergent dosage without pumps cutting out

This alarm goes off if during dosing with a conductometric sensor, the detergent concentration in the tank is not reached within an OFA time set by trimmer **OFA TIME** (POT 4)

The green LED A (**power**) stays on, this LED shows that the WAREPlus is switched on.

- The buzzer sounds intermittently.
- The relay output is enabled.
- The red LED B (*alarm*) flashes.
- The green LED C (*detergent*) stays on.

6.2.3 Over feed alarm OFA2: abnormal detergent dosage with pumps cutting out

This alarm goes off if during dosing with a conductometric sensor, the detergent concentration in the tank is not reached within 2 OFA times.

The green LED A (**power**) stays on, this LED shows that the WAREPlus is switched on.

- The buzzer sounds continuously
- The relay output is enabled
- The red LED B (*alarm*) stays on
- The green LED C (*detergent*) flashes

*Only in the 3 pump systems

7 MAINTENANCE & ACCESSORIES

7.1 MAINTENANCE

Routine maintenance on the **WAREPlus** unit includes keeping the probe clean, keeping pump tubes fresh and keeping the unit clean. Repairs to the unit involve modular component replacements. This minimizes spare parts inventory requirements and speeds up the service process in the field.

7.1.1 Every Maintenance Visit

Titrate wash tank solution to verify unit is holding accurate concentration. Clean the probe if required. Clean the unit cabinet with a damp cloth. Check pump tube condition.

7.1.2 Tubing replacement

- Disconnect the unit from the power supply
- Take the transparent lid off of the pump, removing the front cover screws if necessary
- turn the roller assembly so that the rollers are situated vertically, slide the connection on the left toward you pulling the tube out of its seat and manually rotate the roller assembly clockwise until it is possible to extract the right hand side connection from its seat;
- **to install the tube** turn the roller assembly so that the rollers are lined up horizontally;
- insert the connection in its seat on the left of the pump with the curved side towards the rear of the pump and pushing the tube into its seat while manually rotating the roller housing clockwise until it is possible to insert the right hand side connection into its seat;
- insert the cover starting from the top, with the textured side facing the pump and pushing slightly on the sides until it clicks in place.

7.2 ACCESSORIES

- Pick-up tube with or without level probe.

8 TROUBLESHOOTING

8.1 THE POWER LED (*POWER*) DOES NOT SWITCH ON

- Check fuses on the circuit boards.
- Check input terminals on board for correct input voltage. Refer to the circuit board diagram

8.2 TOO MUCH DETERGENT

- Check the concentration set point for the proper setting.
- Check the probe in the wash tank for corrosion or foreign particles.
- Check for open wires between the probe and the connections to the circuit board

8.3 TOO LITTLE DETERGENT

- Check the concentration set point for the proper setting.
- Check the probe in the wash tank for corrosion or foreign particles.
- Check pump operation for proper speed (or check bowl feeder for obstructions)

8.5 TOO MUCH RINSE AID OR SANITIZER

- Make sure that the dosing time or speed for the pump have not been set at excessively high values.

8.6 TOO LITTLE RINSE AID OR SANITIZER

- Make sure that the dosing time or speed for the pump have not been set at excessively low values.
- Check for possible chemical product leaks on the delivery line.

8.7 ERROR MESSAGES VIA THE LEDS ON THE FRONT PANEL

Refer to paragraph 6.2 of this manual and if necessary contact your local dealer.



WAREPlus Series – Dishwasher systems

10 CONTACT US

Sometimes a problem or a question requires you to call SEKO support. If this happens you can contact us through the telephone numbers listed below. Before calling SEKO support, have available the following, so that the customer support representative can provide a fast and accurate solution to your problem:

- Product model name and number;
- Applicable error messages;
- Detailed specific questions.



Product Purchased in the United States (call weekdays between 8:30 a.m. and 5 p.m. Eastern time):

General Information..... 215 945 0125
Technical Support.1 866 651 4323
Customer Sales & Service.1 866 651 4323



Product Purchased in the United States:
email..... sales@sekousa.com



Contents of this document are subject to change without notice. Every effort has been made to ensure the accuracy of the contents. There is no guarantee to the accuracy or completeness of this document.



Limitation of Liability:

SEKO Dosing System Corp. does not accept responsibility for the mishandling, misuse, or non-performance of the described items when used for purposes other than those specified in the instructions. Seller’s warranty obligations and buyers remedies are solely and exclusively as stated herein. Seller shall have no other liability, direct or indirect, of any kind, including liability for special, incidental, or consequential damages or for any other claims for damage or loss resulting from any cause whatsoever, whether based on negligence, strict liability, breach of contract or breach of warranty.



SEKO Dosing System Corp. Limited Warranty

All Seko controls and pump systems are warranted against defects in material and workmanship for a period of ONE-YEAR. Warranty applies only to the replacement or repair of such parts when returned to the factory with a SEKO number, freight prepaid and found to be defective upon factory inspection. Rubber and synthetic rubber parts such as "O" rings, diaphragms, squeeze tubing and gaskets are considered expendable and are not covered under warranty. Warranty does not cover liability resulting from performance of this equipment nor the labor to replace this equipment. Product abuse or misuse voids warranty. No other warranty, oral, express or implied, including any warranty of merchantability or fitness for any particular purpose, is made for these products, and all other warranties are hereby expressly excluded. Seller’s sole obligation under this warranty will be, at seller’s option, to repair or replace products that meet the terms of this warranty