



CV12 & CV16

Traditional Upright Vacuum Cleaner

Owner's Manual

Operating and Maintenance Instructions

Aspiradora Vertical Tradicional

Manual Del Propietario

Instrucciones de Funcionamiento y
de Mantenimiento

Aspirateur Traditionnel Vertical

Le Manuel du Propriétaire

Instructions d'Utilisation et d'Entretien

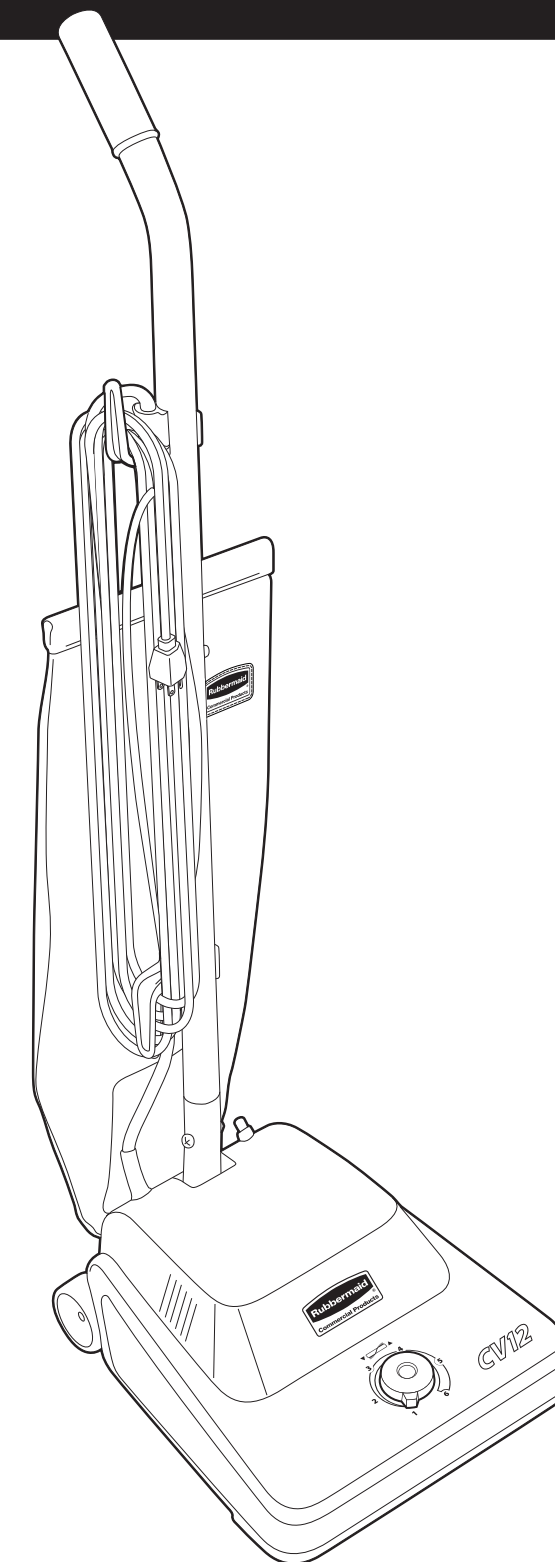

**SAVE THESE INSTRUCTIONS
GUARDE ESTAS INSTRUCCIONES
CONSERVER CES INSTRUCTIONS**

Products manufactured under quality management system registered to ISO 9001:2000
Los productos están fabricados según el sistema de gestión de calidad registrado con la norma ISO 9001:2000
Produits fabriqués selon un système de gestion de la qualité ISO 9001:2000

Printed in China/Impreso en China/Imprimé en Chine
Model no./N.º de modelo/N.º de modèle :
Model No. : 9VCV-12, 9VCV-16
SKU no./N.º de SKU/N.º SKU :
9VCV1200, 9VCV1600



©2008 Rubbermaid Commercial Products LLC
A *Newell Rubbermaid* Company
Rubbermaid Commercial Products LLC
Winchester, VA 22601 U.S.A.
www.rcpworksmarter.com #70-9VCV-12

**FOR COMMERCIAL USE
PARA USO COMMERCIAL
UTILISATION COMMERCIALE**

Customer Service • Atención al Cliente • Service Clientèle
1-866-524-5233
www.rcpworksmarter.com

Work Smarter.



- ENGLISH
- ESPAÑOL
- FRANÇAIS

Congratulations!

Welcome to the world of smarter vacuums. As the proud new owner of Rubbermaid Commercial Product's CV12 or CV16 vacuum cleaner, you can rest assured that you have purchased a convenient, efficient, and high-quality product. As with all of our products, your CV12 or CV16 is backed by our uncompromising commitment to customer satisfaction.

For more Rubbermaid best-in-class products, visit our website at www.rcpworksmarter.com.

Table of Contents

Warranty	3
Troubleshooting	3
Safety Instructions	4
Maintenance.....	5
Electrical Grounding.....	5
Package Contents	6
Parts List	6
Assembled Views.....	7
Reorder Numbers.....	7
Assembly	8
Operation	9
Cord Storage.....	10
Paper Bag Replacement	10
Cloth Bag Replacement.....	11
Belt and Brush Roll Replacement.....	11

One (1) Year Limited Warranty

To the consumer, Rubbermaid Commercial Products, LLC (RCP) warrants to the original owner that this product is free from defects in material and workmanship for a period of one (1) year from the date of the original purchase. If, within the one (1) year period, this product becomes defective when used as directed under normal conditions, RCP will either repair or replace the product—at our option—when it is returned complete (postage prepaid and insured) to an authorized service center. Product must be accompanied by a proof of purchase—a bill of sale, receipted invoice, or other proof that the product is within the warranty period—to obtain warranty service. RCP shall bear the cost of repairing/replacing the product and shipping it back to you. **RCP makes no other warranties, express or implied, concerning the product or the merchantability or fitness thereof for any purpose.**

This warranty does not apply to product that has been damaged as a result of improper maintenance, accident or other misuse. This warranty is void if the product is repaired or modified in any way by anyone other than an authorized service center. This warranty also does not cover normal wear items such as the following: brush, brush rolls, switches, belts, bags, filters, power cords, casters, wheels, and gaskets. This warranty does not cover unauthorized repairs. **In no event shall RCP be liable for incidental or consequential damages.**

For product replacement information, or questions regarding replacement parts, please contact customer service directly (within USA & Canada) at 1-866-524-5233.

Legal rights vary from state to state, so the above limitations may not apply to you if precluded by local law.

Troubleshooting

Problem	Reason	Solution
Vacuum cleaner won't run:	1. ON/OFF switch is in "OFF" position.	1. Press switch to "ON" position.
	2. Power cord not firmly plugged into outlet.	2. Ensure that plug is securely inserted into electrical outlet.
	3. Blown fuse or tripped breaker.	3. Replace fuse/reset breaker.
	4. Motor does not work.	4. Please contact customer service or authorized service center.
	5. Broken fan.	5. Please contact customer service or authorized service center.
	6. Broken switch.	6. Please contact customer service or authorized service center.
Vacuum cleaner won't pick up/low suction:	1. Paper bag not installed correctly.	1. Confirm paper bag is installed correctly—See page 10.
	2. Paper bag is full.	2. Replace paper bag—See page 10.
	3. Cloth bag is full or pores are clogged.	3. Replace cloth bag—See page 11.
	4. Brush roll worn.	4. Replace brush roll—See page 11.
	5. Broken or worn belt.	5. Replace belt—See page 11.
	6. Nozzle duct obstructed.	6. Remove obstruction.
	7. Brush roll improperly installed.	7. Check orientation of brush roll endcaps—See page 12, step 4.
Dust escaping from vacuum cleaner:	1. Paper bag is full.	1. Replace paper bag—See page 10.
	2. Paper bag not installed correctly.	2. Confirm paper bag is installed correctly—See page 10.
	3. Cloth bag not installed correctly.	3. Confirm cloth bag is installed correctly—See pages 8 and 11.

ANY OTHER SERVICING SHOULD BE DONE BY AN AUTHORIZED SERVICE REPRESENTATIVE

Customer Service (1-866-524-5233)

In the event further assistance is required, please call the customer service number above, or contact an authorized service center. Proof of purchase will be required before service is rendered. Transportation charges to and from the repair location must be paid by the purchaser. For quick troubleshooting, please go to www.rcpworksmarter.com.

This warranty does not apply outside of the fifty United States and Canada. This warranty excludes repairs to parts or systems resulting from unauthorized modifications made to the vacuum cleaner.

Important Safety Instructions

SAVE THESE INSTRUCTIONS

When using an electrical appliance, basic precautions should be followed, including the following:

⚠ WARNING

Read all instructions before using vacuum cleaner. Use only as described in this manual, and follow all label and marking instructions found on unit. Failure to do so may result in serious injury or death.

TO REDUCE THE RISK OF FIRE, ELECTRICAL SHOCK, OR INJURY:

- Indoor use only. Store indoors.
- Fully assemble before operating.
- **DO NOT** use without dust bags and/or filters installed.
- **DO NOT** leave unattended when plugged in. Unplug from outlet when not in use, and before servicing.
- **DO NOT** use outdoors or on wet surfaces. **DO NOT** handle vacuum cleaner or plug with wet hands.
- Only plug vacuum cleaner into a properly grounded outlet. See grounding instructions.
- **DO NOT** unplug by pulling on power cord. To unplug from an outlet, pull by the plug, not the cord.
- **DO NOT** use with damaged cord or plug.
- **DO NOT** pull or carry by cord, use cord as a handle, close a door on cord, or pull cord around sharp edges or corners. **DO NOT** run vacuum cleaner over power cord. Keep cord away from heated surfaces.
- **DO NOT** use with an extension cord.
- Turn on/off switch to "off" before unplugging.
- **DO NOT** leave power cord lying on floor when not in use. It can become a tripping hazard.
- **DO NOT** use to pick up flammable or combustible liquids. **DO NOT** use in areas where these substances may be present. Electrical devices produce arcs or sparks that can cause explosions. **DO NOT** use anywhere that gasoline is dispensed.
- **DO NOT** use in an enclosed space where flammable, explosive, or toxic vapors are given off by oil base paint, paint thinner, certain mothproofing substances, or in an area where flammable dust is present.
- **DO NOT** pick up toxic/carcinogenic/hazardous materials such as chlorine, bleach, drain cleaner, gasoline, asbestos, pesticides, or lead.
- **DO NOT** pick up any materials that are burning or smoking, such as cigarettes, matches, or hot ashes.
- During use, keep hose, wands, and other openings away from your face and body. Keep hands, feet, hair, loose clothing, and other body parts away from moving parts.
- **DO NOT** put any object into openings. **DO NOT** use with any opening blocked; keep free of dust, lint, hair, or anything that may reduce air flow.
- Only use manufacturer's recommended attachments.
- Use with caution on stairs.
- Use with caution when vacuuming over area rug edges and fringe.
- **DO NOT** allow to be used as a toy. Close attention is necessary during use by or around children.

Important Safety Instructions (cont.)

- If vacuum cleaner is not working as it should—or has been dropped, damaged, left outdoors, or exposed to water—discontinue use immediately and take it to a service center for inspection. Call 1-866-524-5233 to find a location near you.

⚠ WARNING

This product contains chemicals known to the State of California to cause cancer, birth defects, and other reproductive harm. Wash hands after handling.

Maintenance

Proper maintenance of your vacuum cleaner will assure continued effective cleaning performance.

1. Always use genuine Rubbermaid Commercial Products replacement parts.
2. Replace paper bag frequently.
3. Occasionally remove brush roll and clean debris from end caps to keep brush rotating smoothly.

Electrical Grounding

This appliance must be grounded. Should the unit malfunction, grounding provides a path of least resistance for the electric current. This reduces the risk of electric shock. This appliance is equipped with a cord having an equipment-grounding conductor, and a grounding plug. The plug must be inserted into an appropriate outlet that is properly installed and grounded in accordance with all local codes and ordinances.

⚠ WARNING



ELECTRICAL SHOCK HAZARD

Improper connection of the equipment-grounding conductor can result in a risk of electrical shock. Check with a qualified electrician or service person if you are unsure if an outlet is properly grounded. **DO NOT** modify the plug provided with the appliance to fit an outlet, have a proper outlet installed by a qualified electrician.

This appliance is for use on a nominal 120-volt circuit and has a grounding attachment plug that looks like the plug illustrated in the sketch below. Make sure that the appliance is connected to an outlet having the same configuration as the plug. No adaptor should be used with this appliance.

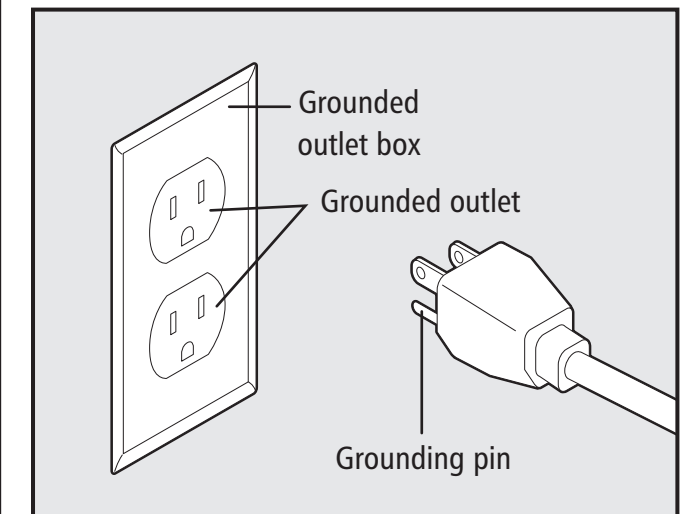

Package Contents

Please confirm that all items shown in the image below are included in the packaging. If any parts are missing, please call customer service at 1-866-524-5233.

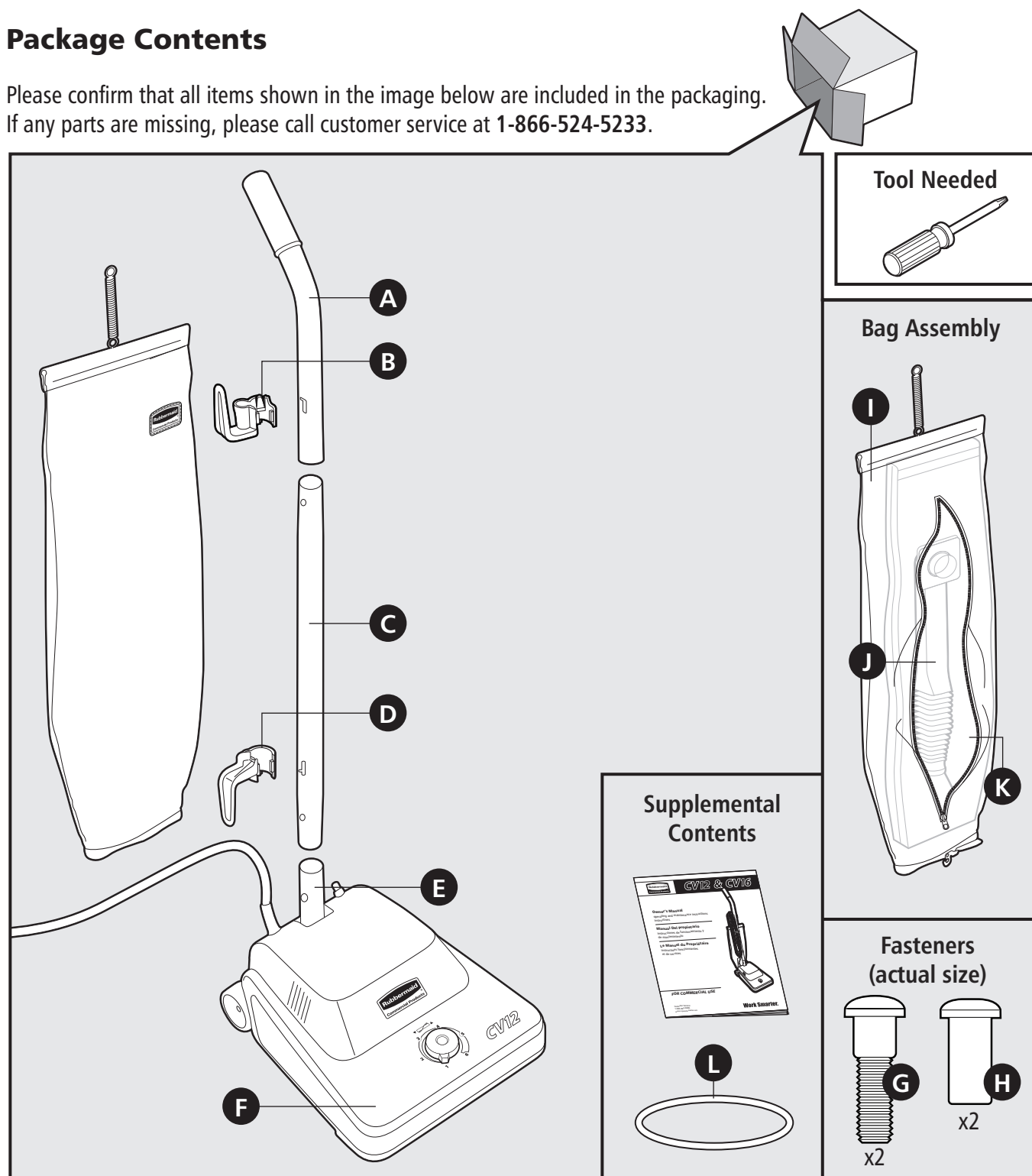

Parts List

- | | | | |
|----------------------------|--------------------------|-----------------------|---------------------|
| A upper handle tube | D lower cord wrap | G male screw | J dirt tube |
| B upper cord wrap | E base stem | H female screw | K paper bag |
| C lower handle tube | F nozzle | I cloth bag | L extra belt |

Assembled Views

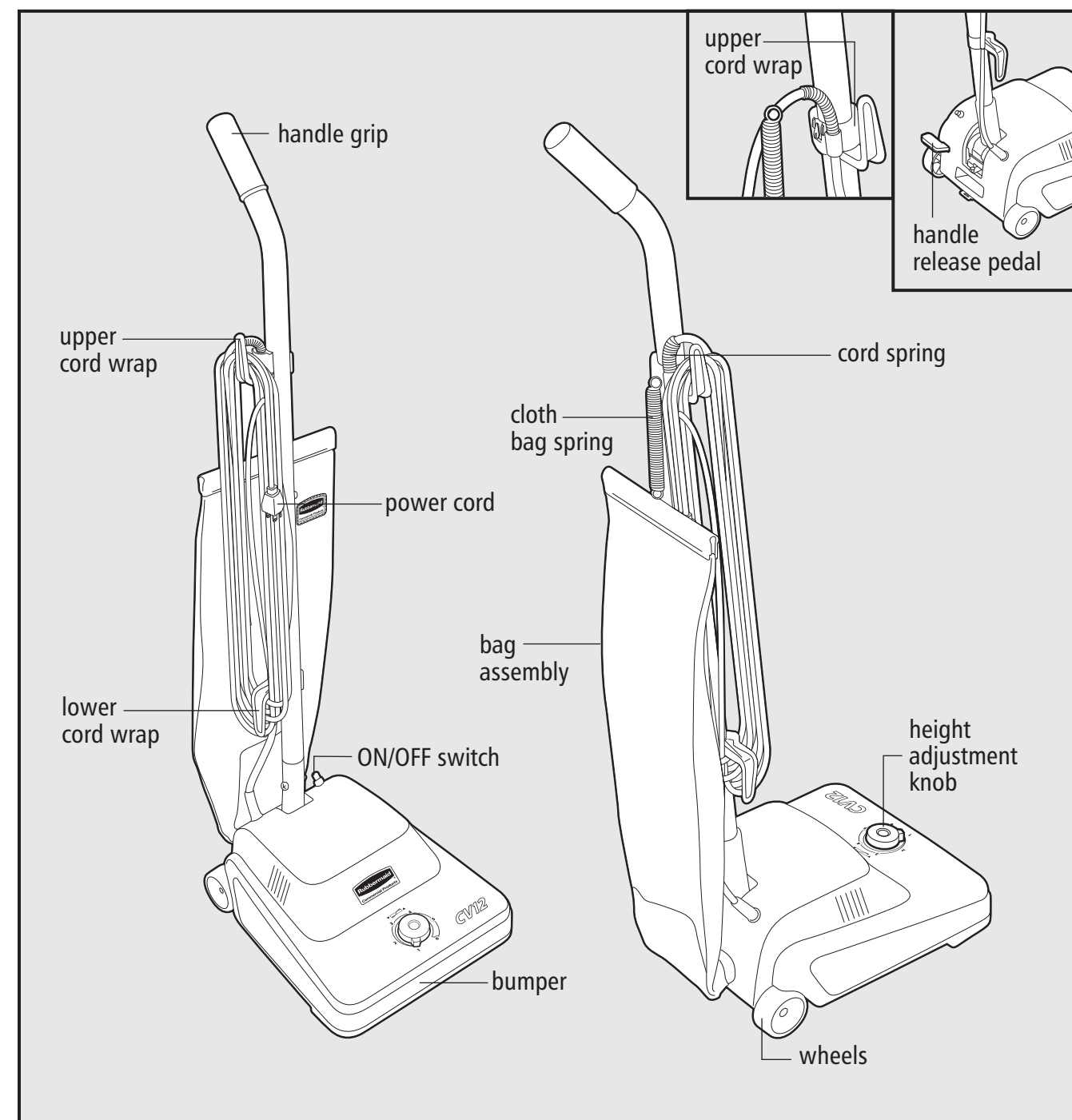

Reorder Numbers

- 9VCVBE12** (belt)
- 9VCVPB12** (paper bag)
- 9VCVBA12** (cloth bag)

Reorder by logging on to www.rcpworksmarter.com or by contacting your local distributor. Call customer service at 1-866-524-5233 for service and to order genuine Rubbermaid Commercial Products replacement parts.

Assembly

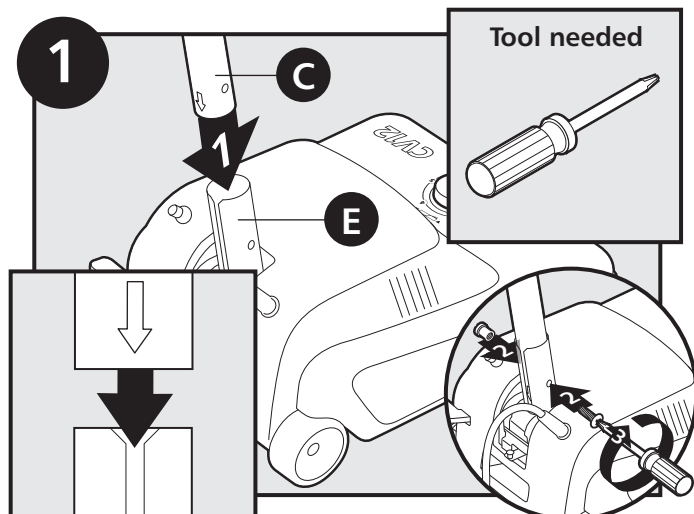

1 Insert lower handle tube into base stem of vacuum cleaner. Align arrow on lower handle tube with slot on base stem. Insert and tighten male and female screws.

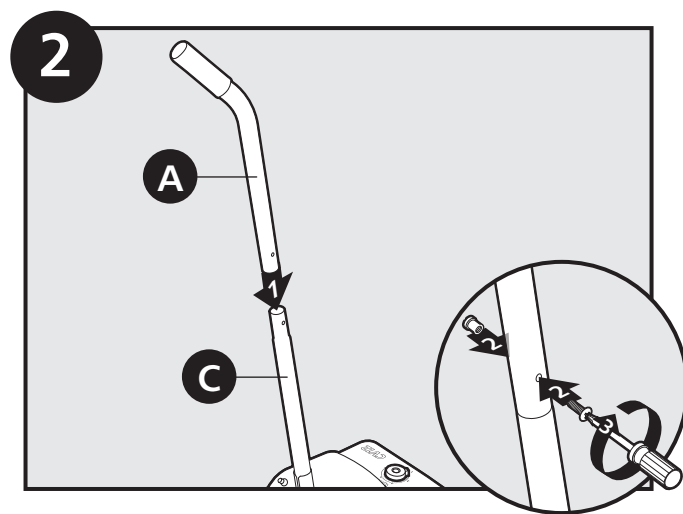

2 Slide upper handle tube over lower handle tube. Position handle with bend facing rear of vacuum cleaner. Insert and tighten male and female screws.

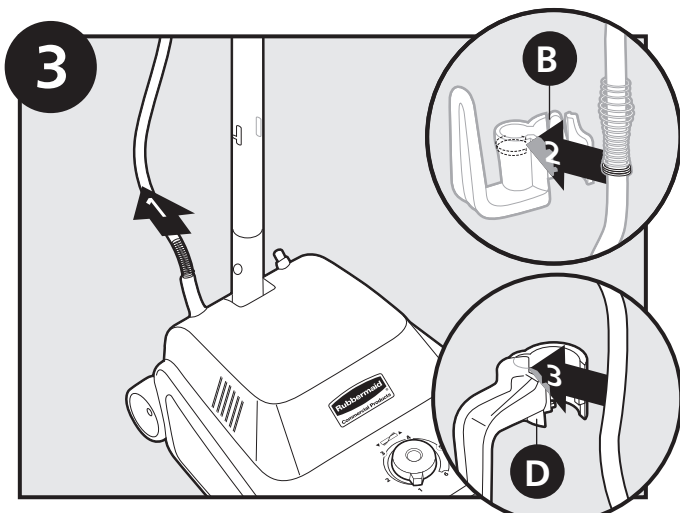

3 Slide cord spring up power cord. Fit bottom of spring into notch in upper cord wrap. Press power cord into notches of upper and lower cord wraps.

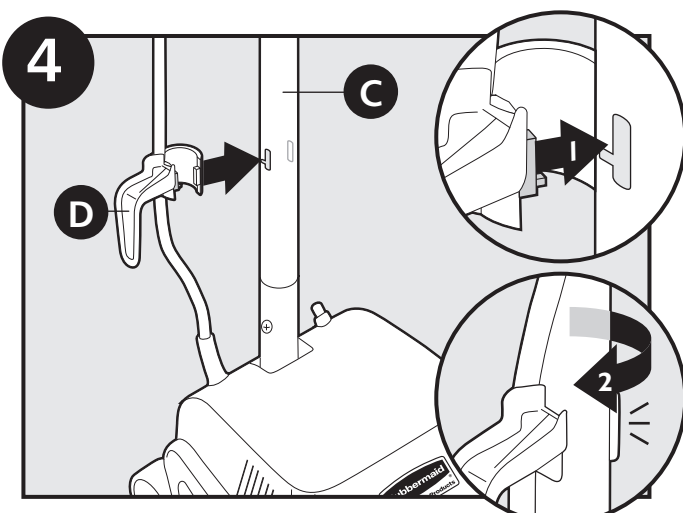

4 Insert keyed tab on lower cord wrap into corresponding keyed hole in lower handle tube. Rotate lower cord wrap onto lower handle tube; snap into place (allowing some slack).

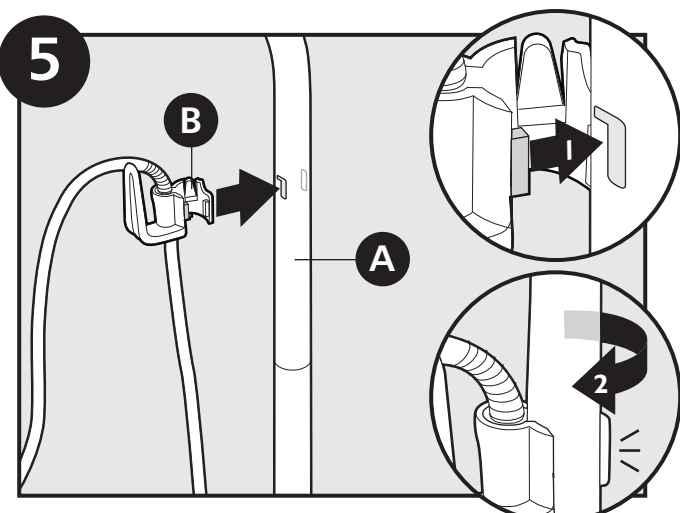

5 Insert keyed tab on upper cord wrap into corresponding keyed hole in upper handle tube. Rotate upper cord wrap onto upper handle tube; snap into place.

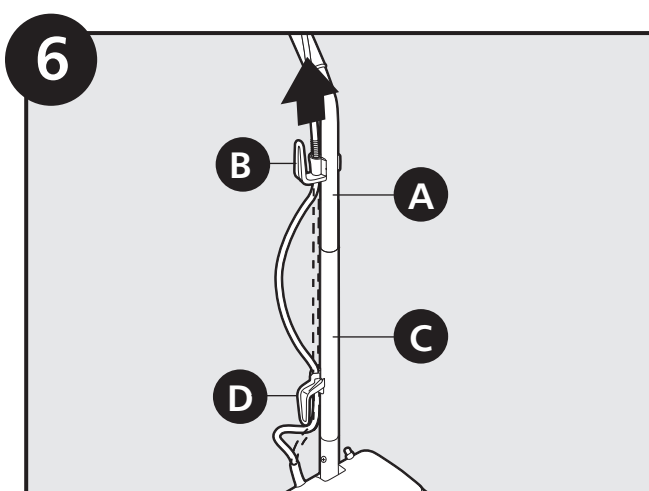

6 Pull power cord through upper cord wrap to remove slack between cord wraps.

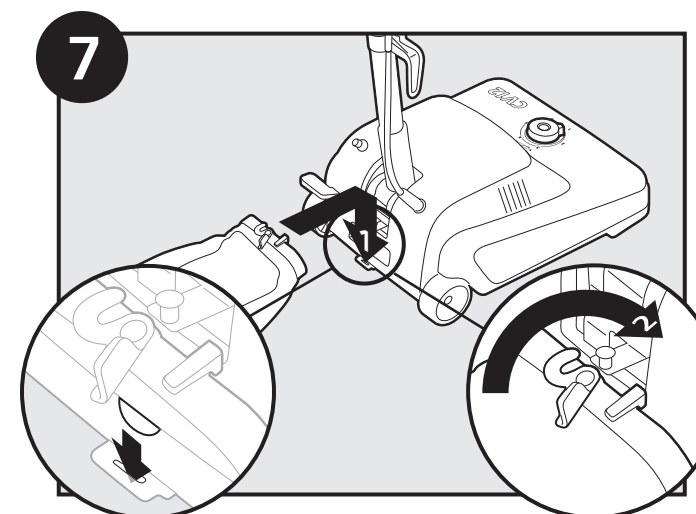

7 Insert tab on bottom of cloth bag into bracket on rear of vacuum cleaner base. Turn latch to engage post on base of vacuum cleaner.

Operation

NOTE:
Fully assemble before operating.

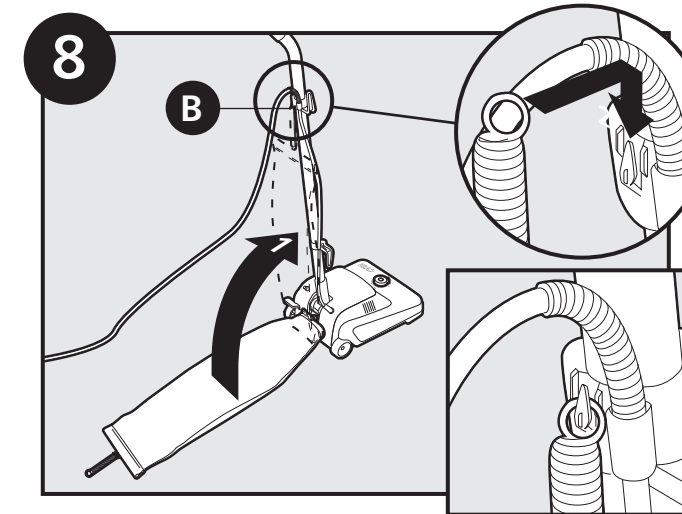

8 Slide ring at top of cloth bag spring onto triangular hook on rear of upper cord wrap. Ensure that the ring slides past rib on hook and snaps over bottom of hook.

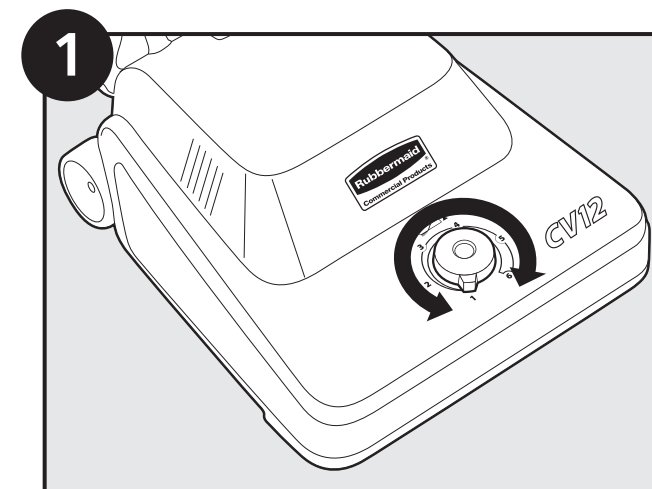

1 Turn height adjustment knob on base to adjust to desired brush roll height.

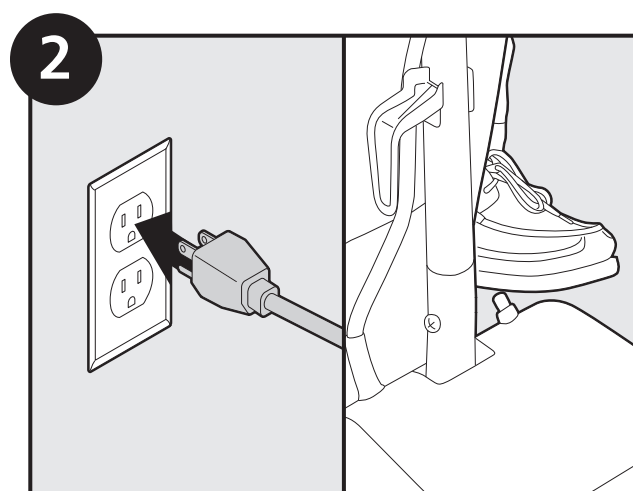

2 Plug power cord into outlet. Use foot to turn power switch "on".

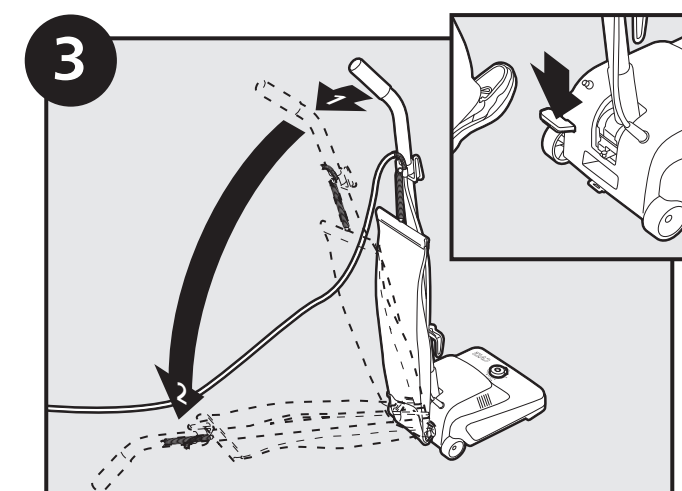

3 To position vacuum cleaner, use foot to press handle release pedal. Press handle release pedal again to lay vacuum cleaner flat.

Cord Storage

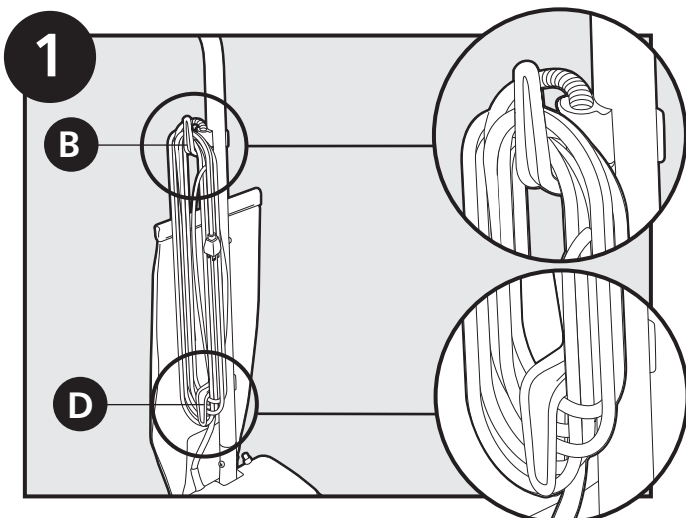

Wrap power cord around upper and lower cord wraps.

Paper Bag Replacement

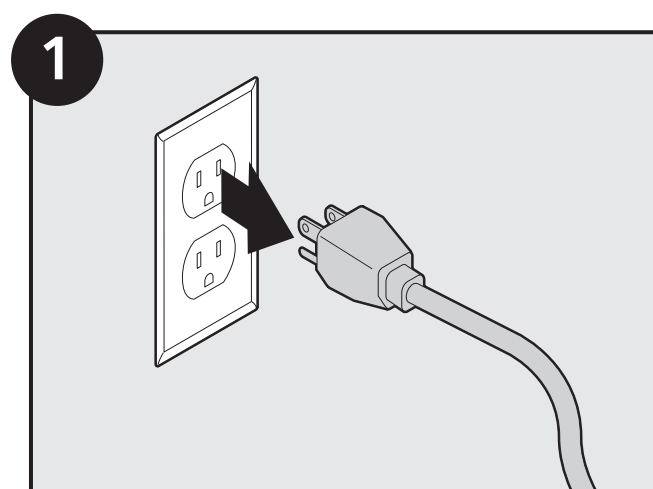

Unplug before servicing.

Cloth Bag Replacement

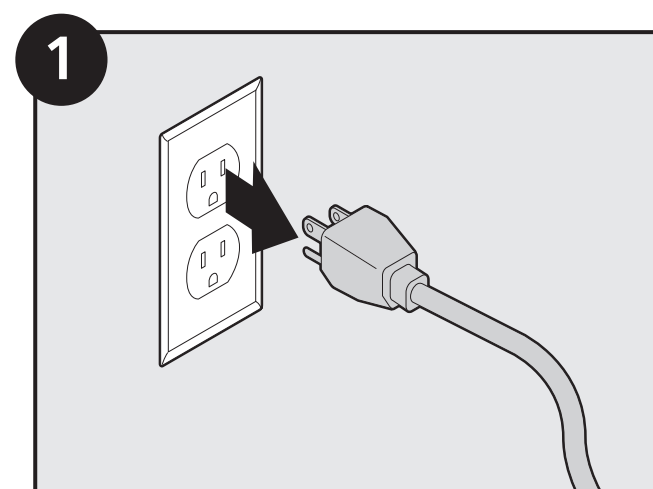

Unplug before servicing.

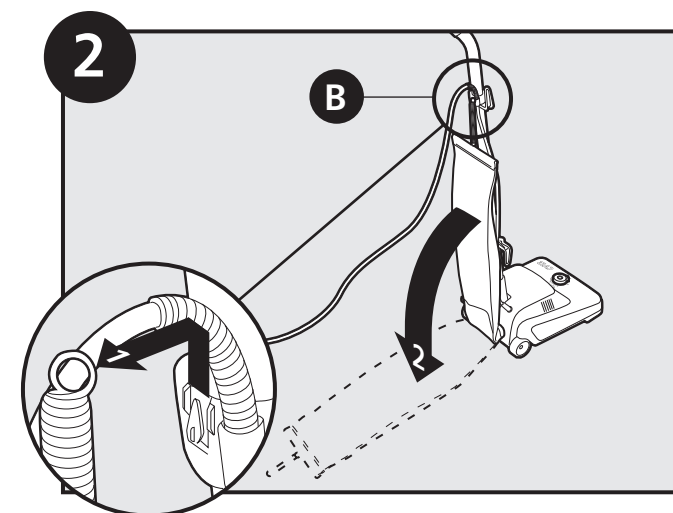

Remove ring at top of cloth bag spring from triangular hook on rear of upper cord wrap. Lay old cloth bag flat on floor.

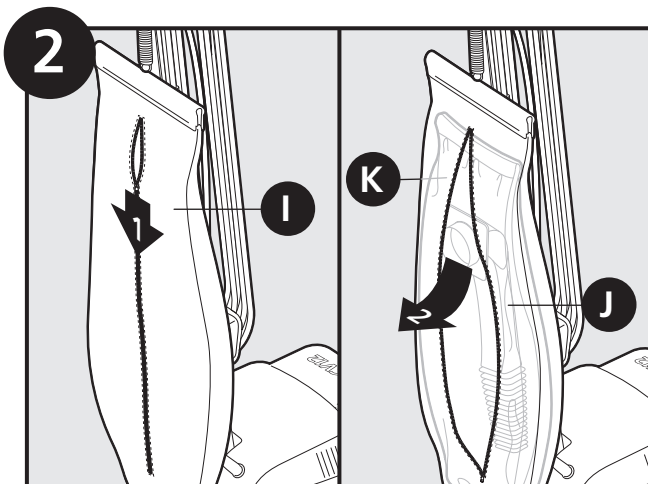

Unzip cloth bag. Pull top of old paper bag and dirt tube out of cloth bag opening.

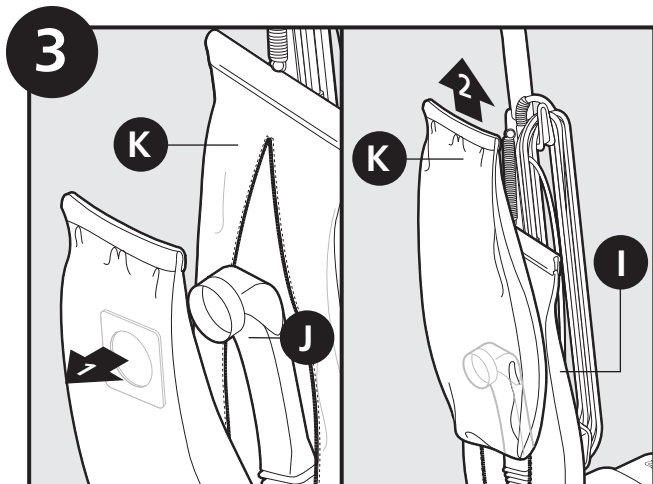

Pull old paper bag off of dirt tube. Remove old paper bag from cloth bag.

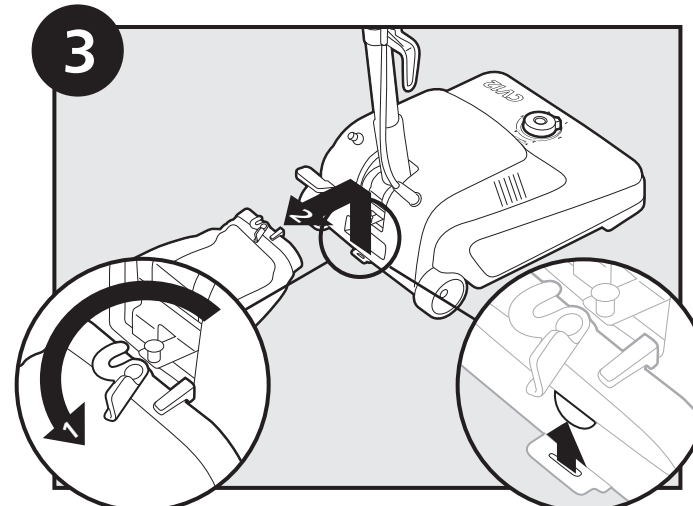

Turn latch to disengage post on base of vacuum cleaner. Remove tab on bottom of old cloth bag from bracket on rear of vacuum cleaner base.

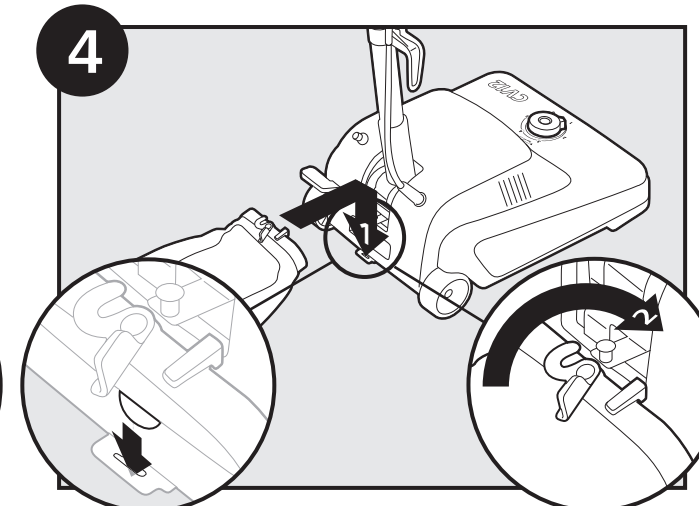

Insert tab on bottom of new cloth bag into bracket on rear of vacuum cleaner base. Turn latch to engage post on base of vacuum cleaner.

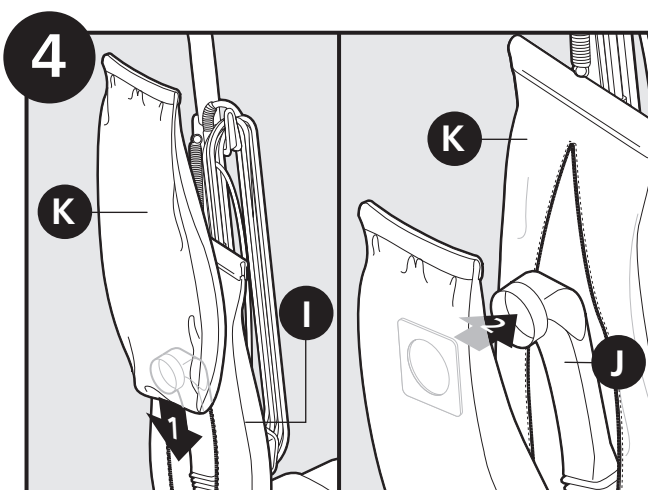

Feed bottom of new paper bag into cloth bag opening. Press new paper bag onto dirt tube over lock tabs.

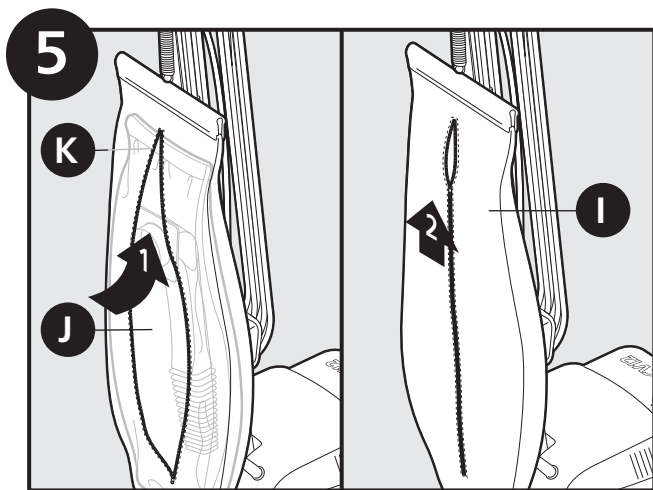

Feed top of new paper bag and dirt tube into cloth bag opening. Rezip cloth bag.

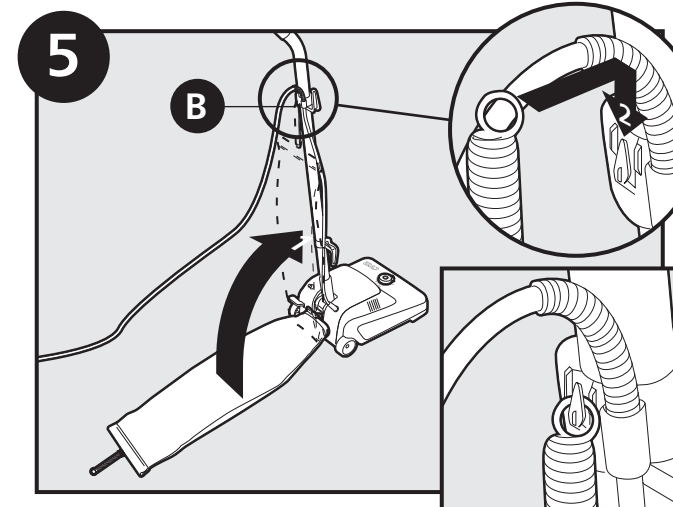

Slide ring at top of cloth bag spring onto triangular hook on rear of upper cord wrap. Ensure that the ring slides past rib on hook and snaps over bottom of hook.

Belt and Brush Roll Replacement

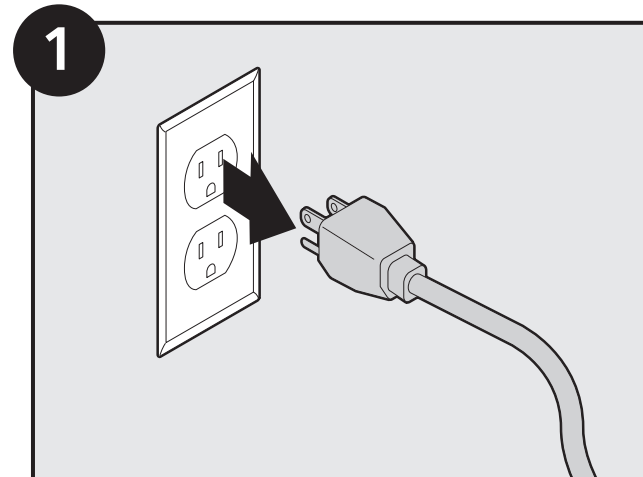

Unplug before servicing.

Belt and Brush Roll Replacement (cont.)

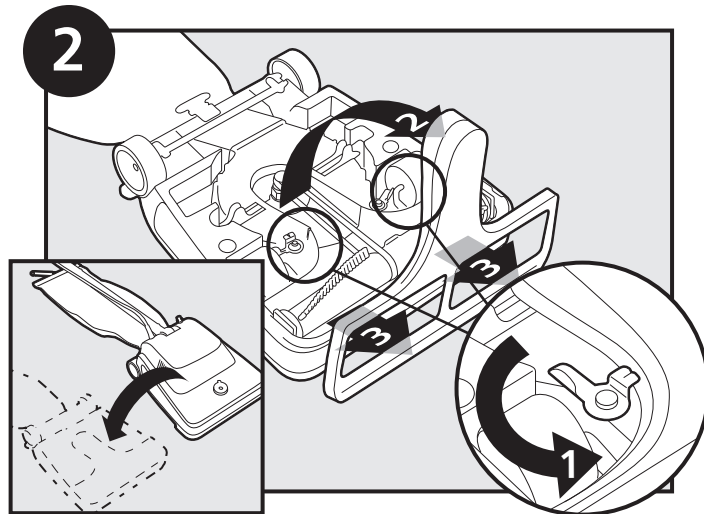

Turn vacuum cleaner over. Turn latches on either side of nozzle guard to release. Remove nozzle guard.

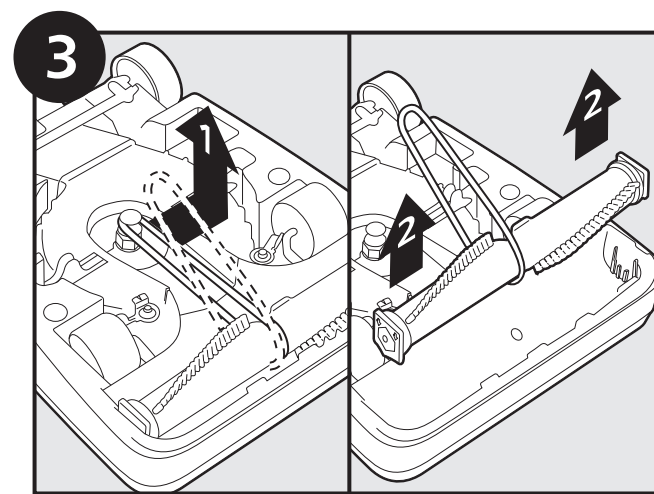

Remove old belt from pulley. Lift brush roll to remove from nozzle opening.

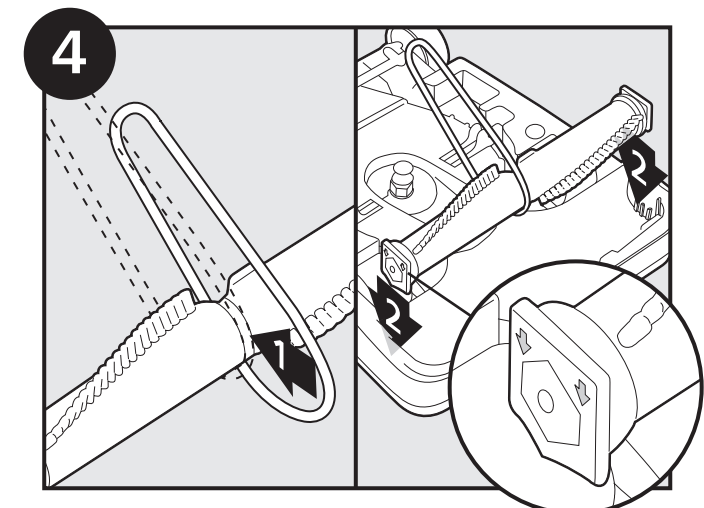

Loop new belt into groove on brush roll. Insert brush roll into nozzle with arrows on brush roll endcaps facing down.

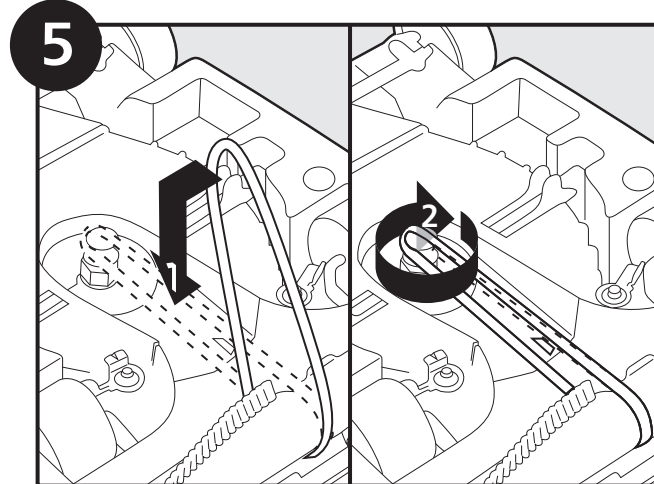

Slide left side of belt onto pulley. Turn pulley clockwise to feed belt into position.

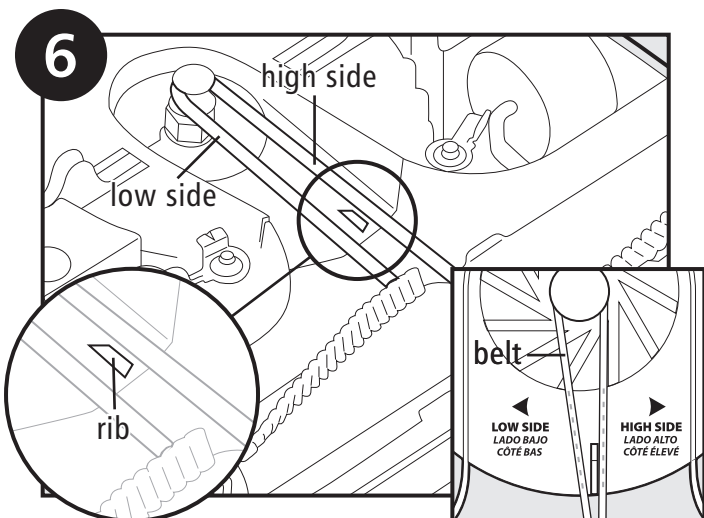

Important: Make sure belt does not touch rib on fan shroud. Low side of belt should be left of rib. (Dotted guidelines are molded onto the fan cover to show proper belt orientation.)

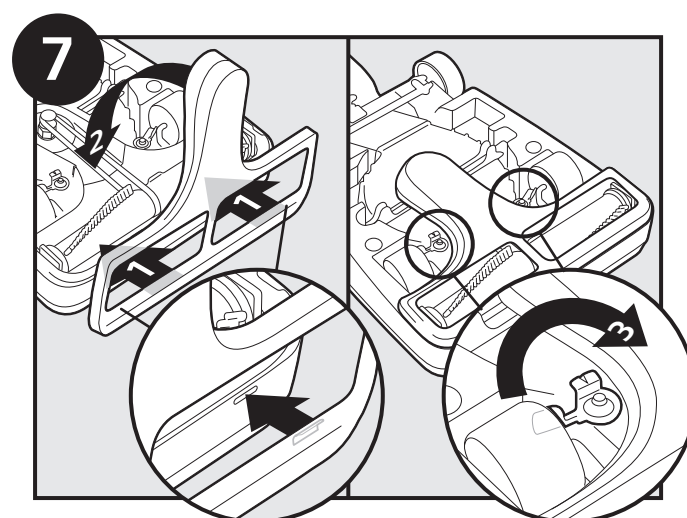

Reinstall nozzle guard from the front, then rotate back. Turn latches to secure.