

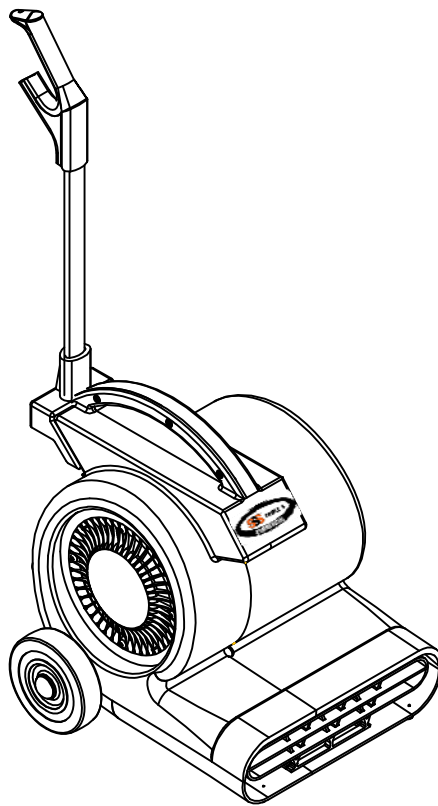

# OWNER'S MANUAL

IMPORTANT: READ OWNER'S MANUAL CAREFULLY



MODEL :

**PUMA**

Shown with optional transport kit

**SS** **TRIPLE S**  
NATIONWIDE  
SANITARY SOLUTIONS  
1-800-323-2251  
[www.triple-s.com](http://www.triple-s.com)

FOR YOUR CONVENIENCE, RECORD THE FOLLOWING  
IMPORTANT INFORMATION

MODEL: \_\_\_\_\_

SERIAL NUMBER: \_\_\_\_\_

DATE PURCHASED: \_\_\_\_\_

PURCHASED FROM: \_\_\_\_\_

## **TABLE OF CONTENTS**

<b>Safety Precautions</b>	<b>3</b>
<b>Machine Operation</b>	<b>4</b>
<b>Machine Maintenance &amp; Storage</b>	<b>4</b>
<b>Parts List</b>	<b>5-9</b>
<b>Wiring Diagram</b>	<b>10</b>
<b>Warranty Policy</b>	<b>11</b>

# Safety Precautions

!!! This machine must be grounded!

Grounding provides a path of least resistance for electrical current. To reduce the risk of electrical shock should the machine malfunction, the machine has a special grounding plug. Don't remove the ground pin under any circumstances!

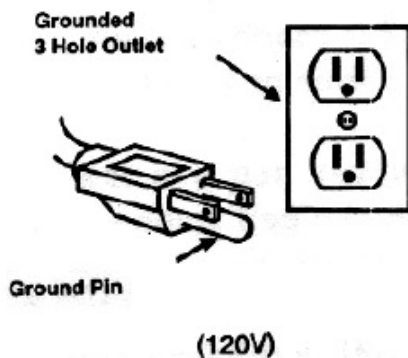

This machine is intended for commercial use. It is constructed for use in an indoor environment and is not intended for any other use. Use only recommended accessories.

All operators shall read, understand and exercise the following safety precautions:

1] Do not operate machine:

- Unless trained and authorized.
- Unless you have read and understand operators manual.
- In flammable or explosive areas.
- With a damaged cord or plug.
- If not in proper operating condition.
- In outdoor areas.

- In standing water
- With the use of extension cords.

2] Before operating machine:

- Make sure all safety devices are in place and operate properly.

3] When using machine:

- Do not run machine over cord.
- Do not pull machine by cord or plug
- Do not pull cord around sharp edges or corners.
- Do not unplug by pulling on the cord.
- Do not stretch cord.
- Do not handle plug with wet hands.
- Keep cord away from heated surfaces.
- Do not pick up burning or smoking debris such as cigarettes, matches or hot ashes.
- Report machine damage or faulty operation immediately.

4] Before leaving or servicing machine:

- Turn off machine.
- Unplug cord from outlet.

5] When servicing machine:

- Unplug cord from outlet.
- Use manufacturer supplied or approved replacements parts.

# Operation of Air Mover

\* Read operators manual thoroughly prior to operating or servicing this machine.

## BASIC OPERATION

1] Check machine for any obstructions in fan prior to operation.

\* If an item blocks the intakes of the blower, this will hurt the performance of the blower, and could cause the motor to overheat.

2] Adjust machine to desired position for operation by either pulling it back to it's preset height adjustments, or by lowering the "kick stand" and setting the machine on the stand.

3] Plug power cord into a grounded outlet.

\* **Do not use an extension cord in conjunction with the standard power cord.**

4] This machine has three power settings Turn the power knob to the desired speed. Low = 1, Med = 2 & High = 3.

5] To stop the machine at any time, simply turn the power knob to the "off" position.

\* **Never stick any object into the air inlet vents or the air outlet vent.**

## MAINTENANCE

To keep the machine performing well for many years, please follow the following maintenance procedures.

\* **Always confirm that the machine is unplugged prior to performing any maintenance or repairs.**

1] Unplug machine as soon as you are done using it.

2] Wrap the power cord around the carrying handle.

3] Check power cord for any damage. If any damage is detected, replace the cord immediately.

4] If you have the wheel kit, lubricate wheels with a water resistant lubricant every month.

5] Check machine for loose or missing nuts and bolts, and replace as necessary.

6] Clean the outside of the machine with a mild cleaner.

## STORAGE

1] Unplug machine from power source.

2] Store in upright position in a dry area.

# Parts List

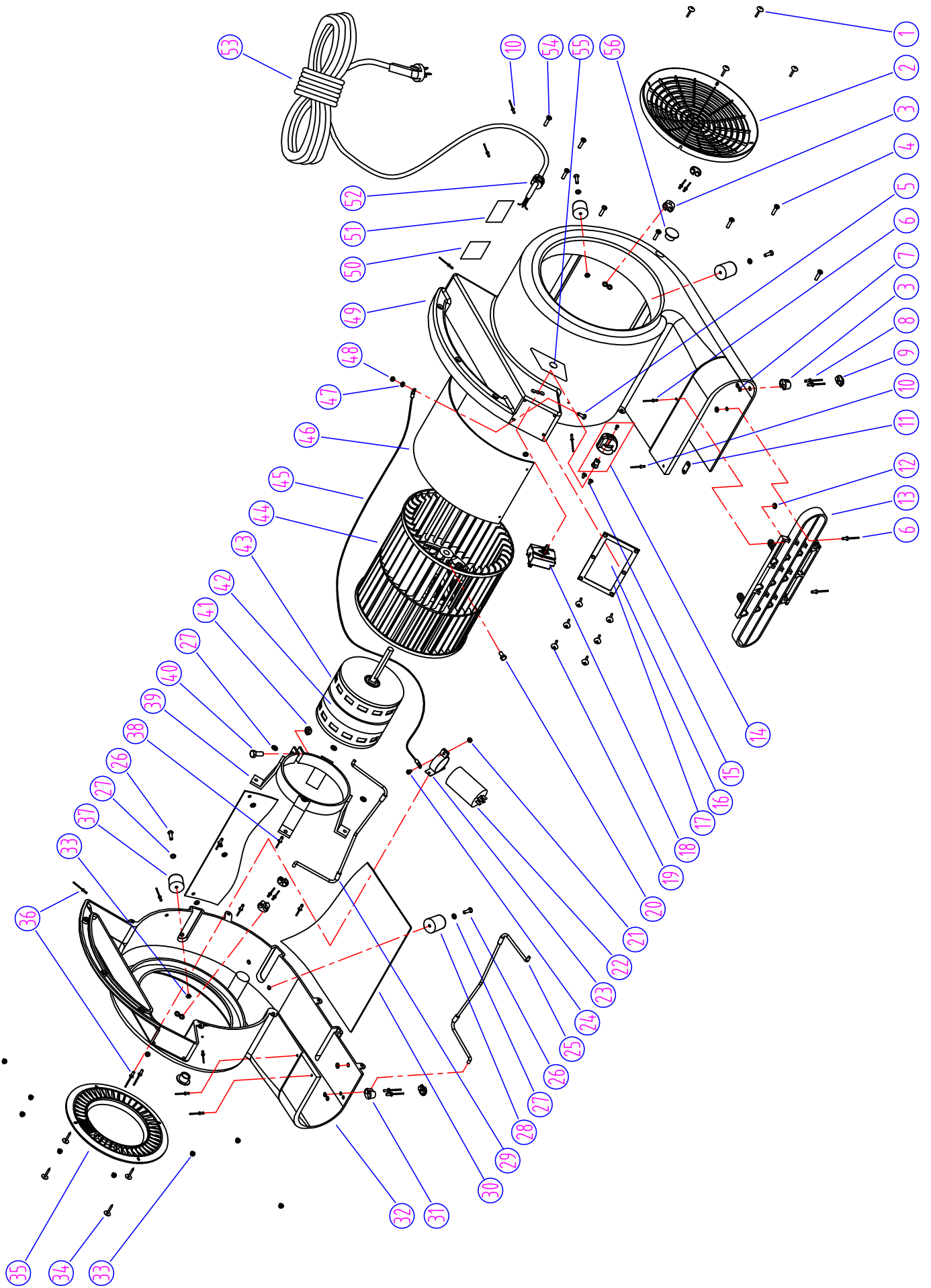

## PARTS LIST

<b>DIA NO</b>	<b>PART NUMBER</b>	<b>DESCRIPTION</b>	<b>NO REQ'D</b>
1	VV13649	SCREW,SELF-TAPPING,ST,M4X25	4
2	VV30107	LEFT NET,VENT,INTAKE	1
3	VV30102	BLOCK,STAND,RIGHT FRONT	2
4	VF13613	SCREW,M5X20	8
5	VF14070	SCREW,M4X25	1
6	VV13647	RIVET,M4.8X18	4
7	VV13653	WASHER,PLAIN,M3.5XM10X1.0	15
8	VV13645	RIVET,M3.2X16	4
9	VV30124	RUBBER,BLOCK,STAND	2
10	VV20352	RIVET,M4X12	2
11	VV30119	CONNECTING PLATE	1
12	VA13482	WASHER,PLAIN,M5.0XM11X1.0	4
13	VV30112	NET,VENT,OUTLET	1
14	VF30015	ROTATOR,SWITCH,KIT	1
15	VV13658	SCREW,SWITCH,M5X20	2
16	VV30500TR	PLATE LABEL	1
17	VV30103	PLATE	1
18	VV30180	SWITCH	1
19	VV13608A	SCREW,SELF-TAPPING,ST,M4X12	6
20	VV13656	SCREW,M8X16	1
21	VV13609	NUT,M4	1
22	VV30143	CAPACITOR,30UF/300V	1
23	VV30014	CLAMP,CAPACITOR	1
24	VV13642	SCREW,M4X8	1
25	VV30115	STAND	2
26	VA13475	SCREW,M5X25	4
27	VV13662	WASHER,PLAIN,M5XM12X1.0	8
28	VV30114-1	RUBBER,STAND,38mm	2
29	VV30117	SLEEVE,RUBBER	2
30	VV30118	PLATE,CHAMBER	1
31	VV30200	BLOCK,STAND,LEFT FRONT	2
32	VV30100A	HOUSING,LEFT	1
33	GT13022	NUT,LOCK,M5	15

## PARTS LIST

<b>DIA NO</b>	<b>PART NUMBER</b>	<b>DESCRIPTION</b>	<b>NO REQ'D</b>
34	VV13640	SCREW,SELF-TAPPING,ST,M4X16	4
35	VV30110	RIGHT NET,VENT,INTAKE	1
36	VV13655	RIVET,M3.2X12	9
37	VV30114	RUBBER,STAND,48mm	2
38	VV13648	RIVET,M6.4X18	4
39	VV30011	CLAMP,MOTOR	1
40	VV13657	SCREW,M8X25	1
41	VF13503	NUT,LOCK,M8	1
42	VV30116	GASKET,MOTOR	1
43	YQ61000	MOTOR,120V,3/4HP	1
44	VV30010	IMPELLER,9"	1
45	VA21570	CABLE,200mm	1
46	VV30118A	PLATE,CHAMBER	1
47	VF13527	WASHER,TOOTH,M4	3
48	VV20249	NUT,M4	4
49	VV30101A	HOUSING,RIGHT	1
50	VV30202	READ MANUAL,LABEL	1
51	VV30505TR	SERIAL TAG	1
52	VV30182	POWER BUSHING	1
53	VV30183U	POWER CORD	1
54	VV13636	SCREW,M5X30	3
55	VV30529	LABEL,SWITCH	1
56	VV30122	COVER,AXLE	2

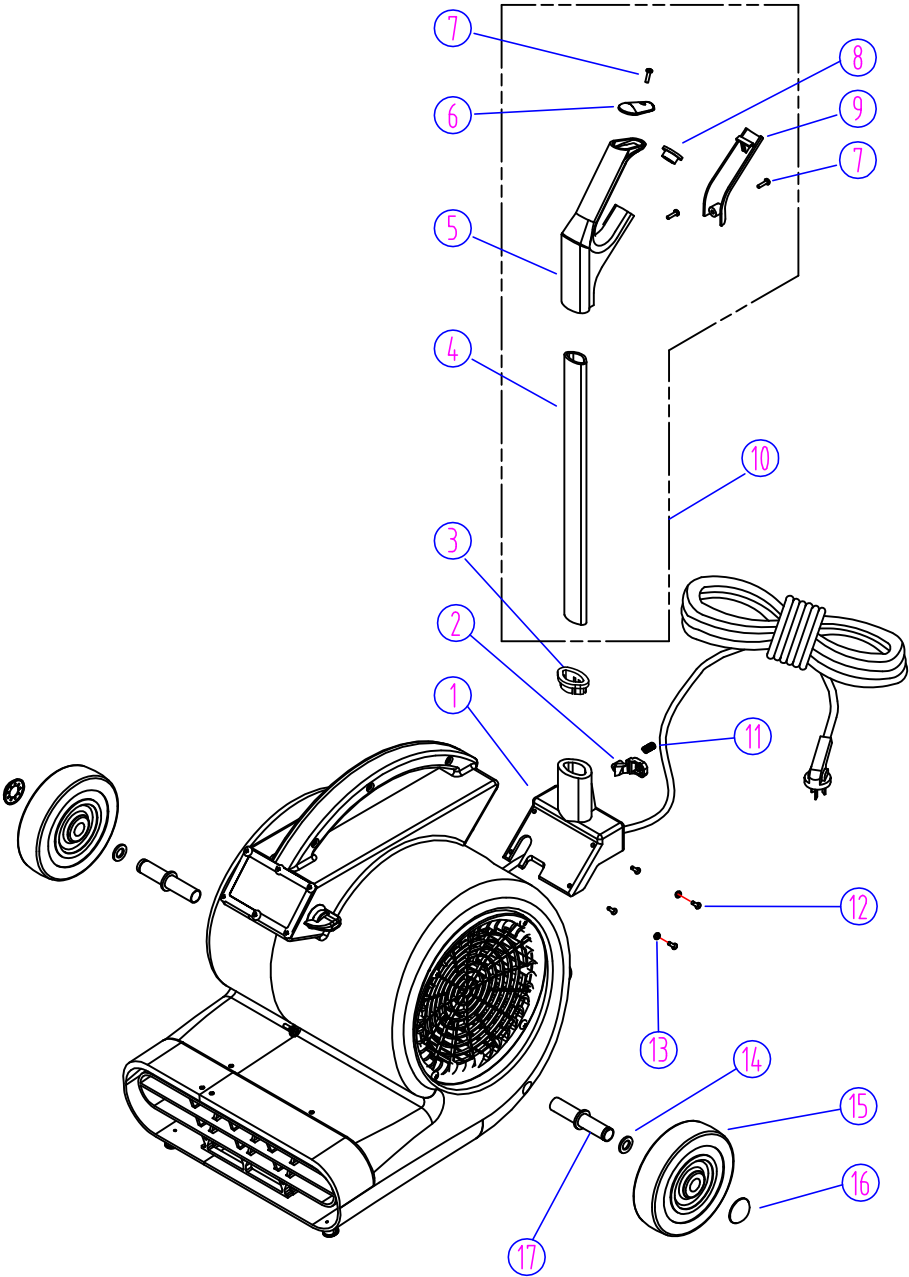

**THE AXLES HAVE A VERY TIGHT TOLERANCE FIT.  
LUBRICATE THEM WITH SOME SOAPY WATER BEFORE  
DRIVING THEM INTO THE MOLDED RECEIVER.**



**PARTS LIST**

<b>DIA NO</b>	<b>PART NUMBER</b>	<b>DESCRIPTION</b>	<b>NO REQ'D</b>
1	VV30120	SEAT,HANDLE	1
2	VV30130	RELEASE BUTTON	1
3	VV30121	COVER,HANDLE SEAT	1
4	VV30106A	TUBE,AL	1
5	VV30132	PLASTIC HANDLE	1
6	VV30134	COVER,HANDLE	1
7	VV13640	SCREW,SELF-TAPPING,ST,M4X16	3
8	VV30123	RUBBER COVER,HANDLE	1
9	VV30133	BOTTOM,HANDLE	1
10	VV30109B	HANDLE ASSEMBLY	1
11	VV30131	SPRING,RELEASE BUTTON	1
12	VV13661	SCREW,M4X12	4
13	VV13664	WASHER,PLAIN,M4XM12X1	4
14	VF47027	WASHER,LOCK	2
15	VF47055BD	WHEEL,6.4"	2
16	VA96851	CAP,AXLE	2
17	VV30111	AXLE	2

# Wiring Diagram

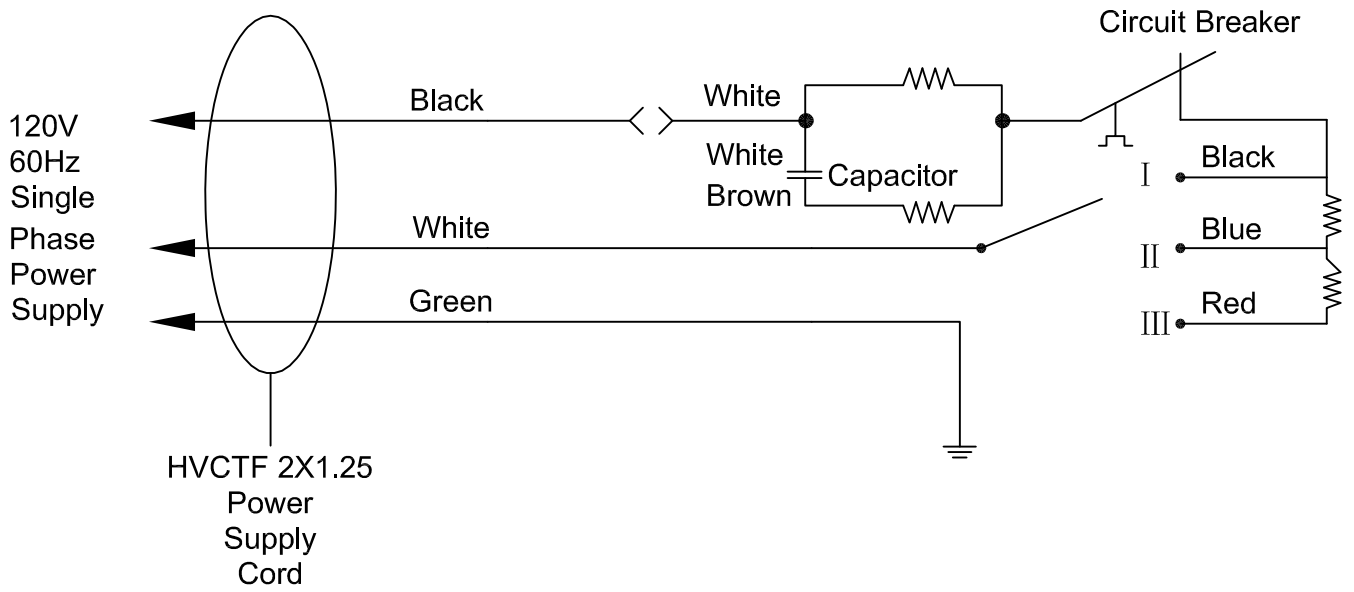



## Warranty Policy

The warranty terms outlined below are in lieu of any other warranties, either stated or implied, including any implied warranty of merchantability, fitness for a particular purpose or otherwise. Under no circumstances will seller be liable for any loss, damage, expense or consequential damages arising in connection with the use or inability to use this product.

This warranty does not apply to damage or defect caused by accident, misuse, negligence, abuse, fire or to any Triple S product which has been serviced by anyone other than a Triple S authorized service representative. Housings or parts that have become damaged as a result of improper use of the machine are excluded from this warranty. Refer to owner's manual for proper machine use and maintenance. Parts that are expected to wear from normal use and, therefore are not covered under the parts warranty include, but are not limited to: batteries (pro-rated for one year); bearings; belts; brushes; filters; squeegees; switches; and tires.

This warranty commences on the date of purchase of the product by the original end user from an authorized Triple S distributor, subject to proof of purchase. If proof of purchase date is unavailable, the warranty begins 90 days after the sale of the product to an authorized Triple S distributor.

- Subject to the conditions outlined above, the manufacturer warrants the rotationally-molded polyethylene housings and parts on its machines to be free from defects in materials and workmanship, under normal use and service for twelve (12) years to the original purchaser.
- Under this warranty, the manufacturer guarantees the performance of non-polyethylene parts and components on Triple S machines to be free from defects for up to five (5) years to the original end user. Parts replaced under this warranty are guaranteed for the remainder of the original warranty period.
- Labor charges are covered for two (2) full years from the date of purchase for Triple S products, provided an authorized Triple S service provider is used for repair. No travel coverage is extended for cord electric machines.

Product Exceptions & Exclusions: Battery chargers and all accessories are warranted for one year.

*Triple S reserves the right to change the warranty policy without notice.*