

MS-12 12-Inch Mini Scrub Autoscrubber Parts Lists and Schematic Drawings



Index

Cover	Page 2
Handle Housing	Page 3
Vacuum Motor	Page 4
Pump Assembly	Page 5
Wheels	Page 6
Suction Nozzle	Page 7
Brushes	Page 8
Wiring Diagram	Page 9





MS-12 12-Inch Mini Scrub Autoscrubber Cover Parts List and Schematic Drawing

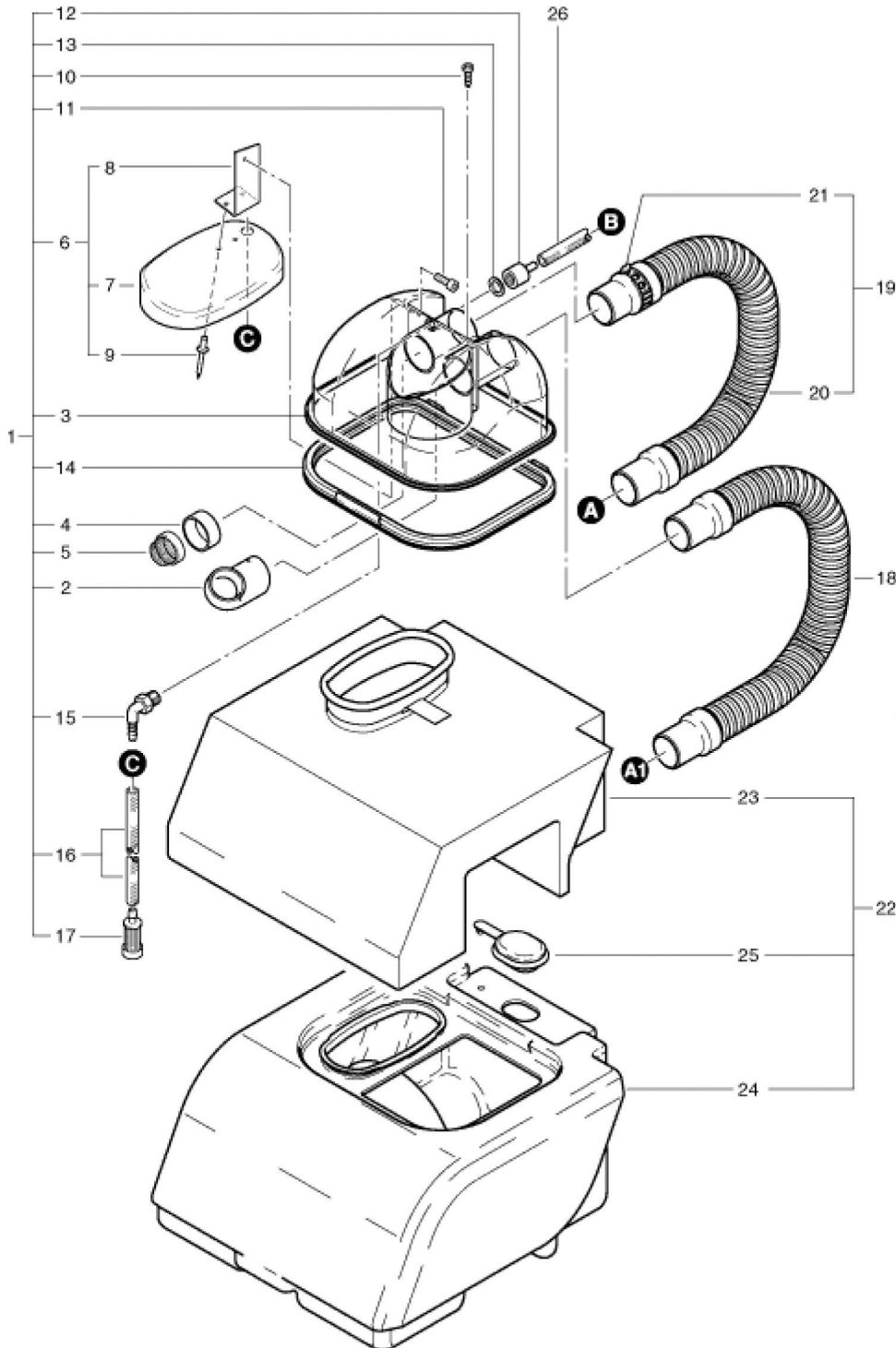

Pos.	Description	Reference
01	Tank cover complete - including: items 2-17	300.700
02	Bent tube	380.552
03	Tank cover	380.510
04	Ring for filter	380.556
05	Filter	400.766
06	Partition complete - including: items 7-9	300.580
07	Clean water tank cover	300.584
08	Angle	300.585
09	Blind rivet dm 4x8 mm	P...485 C
10	PT screw KA 30x6	P...515 Y
11	Hexagon socket screw M 3x10	P...487 Y
12	Fitting SW22 G3/8"	380.555
13	Gasket	030.015
14	Seal for cover	380.554
15	Angled fitting G1/4"	P...541 I
16	Hose 6/12 x 250 mm	300.703
17	Fresh water filter	P...528
18	Complete hose compl.	300.743
19	Suction motor hose compl. - including: items 20+21	380.740
20	Hose	380.743
21	Air control slide	380.745
22	Tank complete - including: items 23-25	300.550
23	Fresh water tank	300.722
24	Tank	300.560
25	Cover	300.731
26	Suction hose 12x530	300.072



MS-12 12-Inch Mini Scrub Autoscrubber Handle Housing Parts List and Schematic Drawing

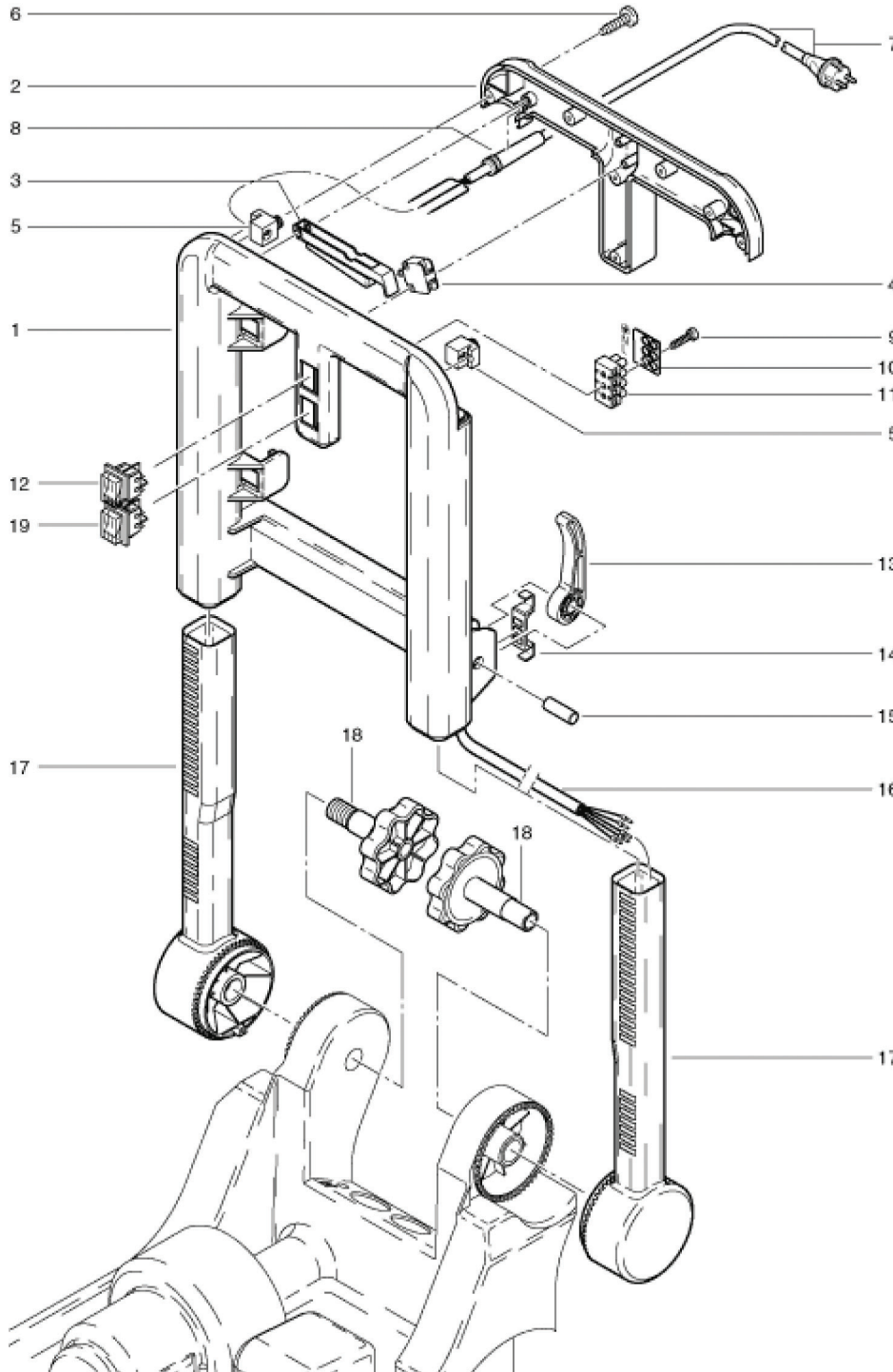

Pos.	Description	Reference
01	Handle housing	300.610
02	Cover for handle	300.620
03	Controlling lever	380.267
04	Switch	950.453
05	Cable tightener	380.252
06	PT-screw KA 40x16 mm	P...516C
07	Mains cable Europe	P...276
07	Mains cable Switzerland	P...275
07	Mains cable England	P...276A
08	Cable grommet	P...280
09	PT-screw KA 30x18 mm	P...515A
10	Marking plate	P...394
11	Electrical terminal (4)	P...383B
12	Tumbler switch	P...240
13	Fixing lever	380.262
14	Fixing plate	380.259
15	Pin	380.265
16	Cable	300.315
17	Lower lever	300.615
18	Star handle	380.276
19	Tumbler switch	P...240H

MS-12 12-Inch Mini Scrub Autoscrubber Vacuum Motor Parts List and Schematic Drawing

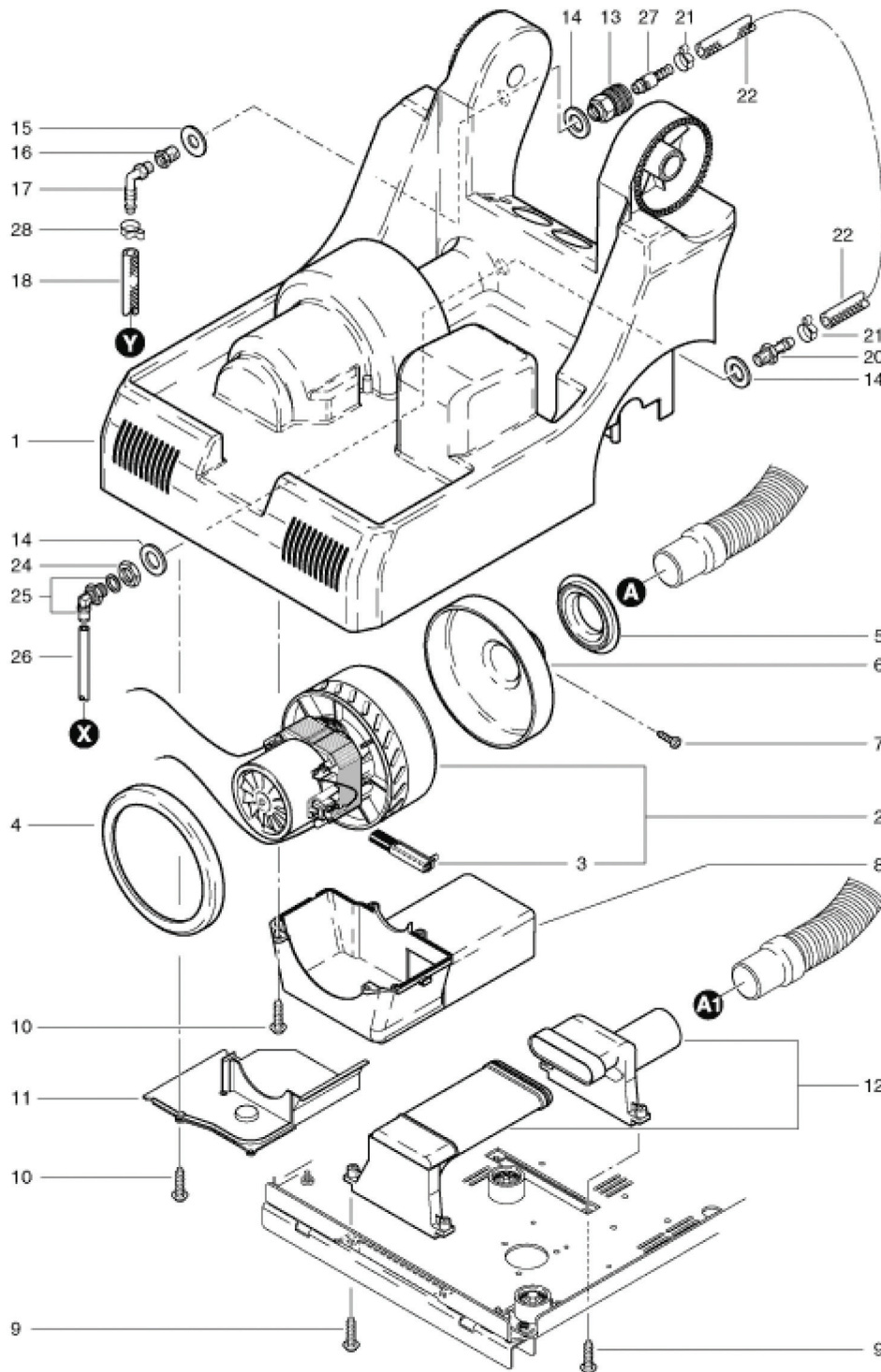

Pos.	Description	Reference
01	Chassis cover	300.052
02	Suction motor	P...870C
03	Pair of Charbon brushes	P...870X
04	Motor sealing ring	P...971C
05	Sealing ring	380.019
06	Hose connection cap	380.021
07	Screw 2.9x9.5 mm	P...483H
08	Motor cover	380.017
09	PT-screw KA 50x16 mm	P...515Z
10	PT-screw KA 40x18 mm	P...516C
11	Air canal cover	380.022
12	Air canal compl.	300.410
13	Coupling	380.045
14	Security ring	P...098
15	Washer M12	P...496A
16	Reducer	P...521E
17	Angled connector	P...541R
18	Pressure hose 6/12x420 mm	300.178
20	Connecting nipple	300.088
21	Hose clamp 14.5 mm	P...550A
22	Connection hose 250 mm	300.172
24	Hexagon nut 3/8««	P...535B
25	Angled connector	P...533C
26	Connection hose 640 mm	300.165
27	Straight nipple with reducer	300.085
28	Hose clamp 13.3 mm	P...550I

MS-12 12-Inch Mini Scrub Autoscrubber Pump Assembly Parts List and Schematic Drawing

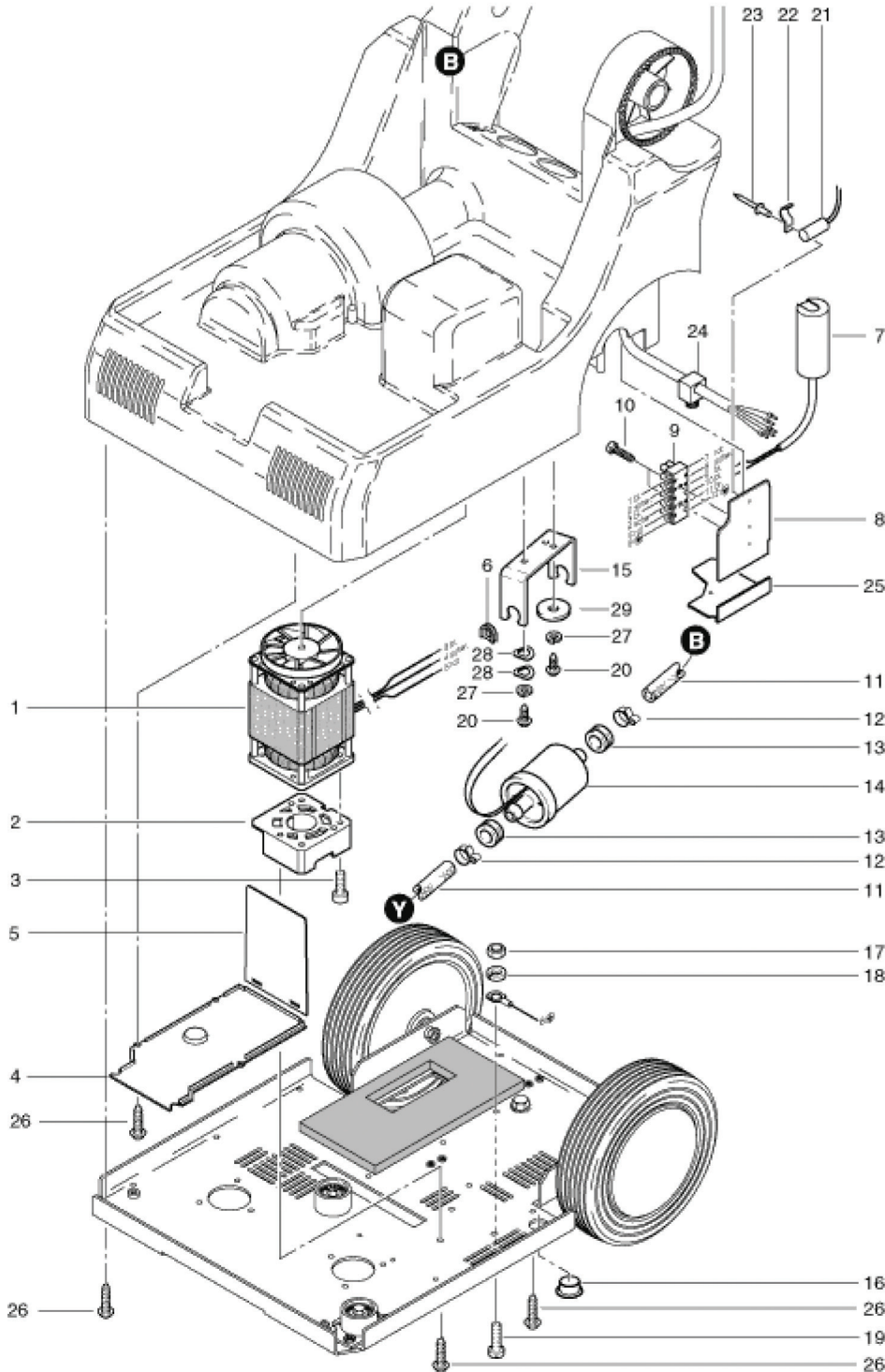

Pos.	Description	Reference
01	Brush motor	300.281
01	NDS-L - pump 220-240V 50Hz	P...815
01	NDS-L - pump 24V DC	P...815 L
02	Motor fixing plate	300.357
02	Ring	P...815 H
03	PT-screw KA 40x16 mm	P...516G
03	Cover	P...815 B
04	Air canal cover	300.058
04	Counter ring	P...809 N
05	Air canal plate	300.061
05	Valve spring	P...809 P
06	Rubber clamp	P...014A
06	Valve cone	P...810 S
07	Capacitor 5uF	P...385I
07	Valve seating	P...809 Q
08	Plate for electrical terminals	380.047
08	O-ring 12x1,5 mm	P...809 L
09	Electrical terminal (6)	P...383C
09	O-ring 14x1,5 mm	P...809 K
10	Screw KA 30x14 mm	P...516S
10	Counter ring	P...815 X
11	Suction hose 12/6x530 mm	300.072
11	Piston	P...809 B
12	Hose clamp 14.5 mm	P...550A
12	Pressure spring for piston	P...809 E
13	Rubber clamp	P...207A
13	Housing pipe	P...815 D
14	NDS-L pump	P...815
14	Spring support	P...809 F
15	Pump holder	P...207B
15	Raising NDS-L	P...815 A
16	Cover	P...171N
16	Spring support compl. Including: items 8,9+14	P...810 X
17	Hexagon nut M4	P...491Q
17	Valve seating compl. Including: items 4-9	P...810 Y
18	Spring ring M4	P...498A
19	Pan head screw M 4x12 mm	P...476L
20	PT-screw KA 30x6 mm	P...515Y
21	Capacitor 0.2uF	P...387A
22	Holder for capacitor	P...109C
23	Blind rivet 3x6 mm	P...485H
24	Cable tightener	380.251
25	Cover for electrical terminals	380.048
26	PT-screw KA 40x16 mm	P...516C
27	Spring ring M4	P...498A
28	Spring ring M6	P...497W
29	Washer 6/25x1.8 mm	P...497Y

MS-12 12-Inch Mini Scrub Autoscrubber Wheels Parts List and Schematic Drawing

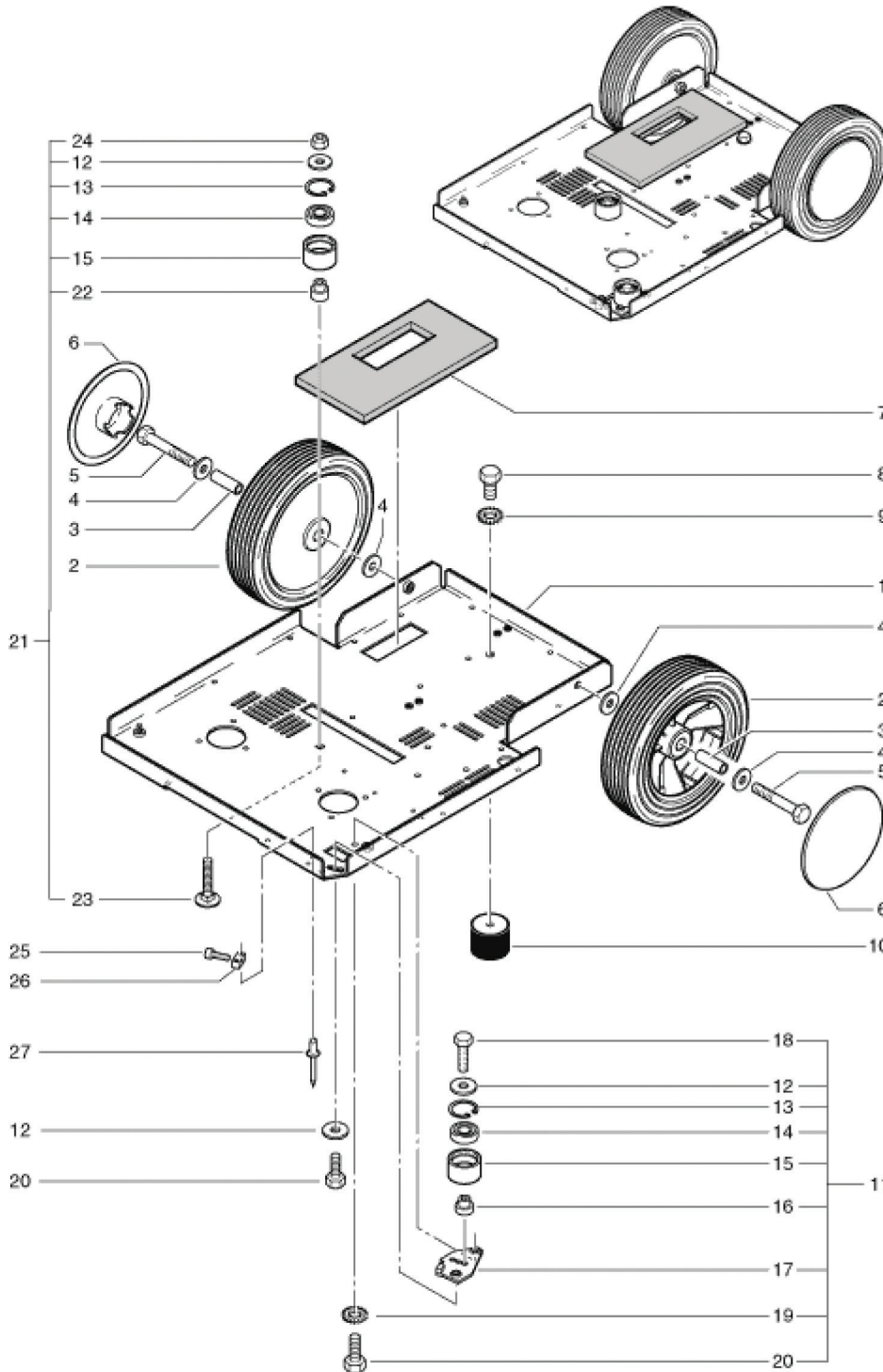

Pos.	Description	Reference
01	Bottom plate	300.111
02	Wheel	380.135
03	Distance piece	380.137
04	Washer M8	P...496Q
05	Hexagon screw M 8x55 mm	P...471K
06	Wheel cover	300.242
07	Isolation	300.065
08	Hexagon screw M 8x10 mm	P...471B
09	Serrated lock washer M8	P...498G
10	Round buffer	300.118
11	Idler pulley compl. - including: items 12-20	300.375
12	Washer M6	P...496L
13	Retaining ring dm 28 mm	P...499G
14	Ball bearing	P...316J
15	Pulley d 34x20 mm	300.378
16	Bearing pin d 18/12x14.7 mm	300.377
17	Fixation for pulley	300.161
18	Hexagon screw M 6x20 mm	P...472T
19	Serrated lock washer M6	P...499D
20	Hexagon screw M 6x12 mm	P...472R
21	Guide pulley - including: items 22-24	300.385
22	Bearing pin	300.388
23	Screw M 6x30 mm	P...481G
24	Stop nut M6	P...493K
25	Hexagon socket screw M 4x14 mm	P...486F
26	holder for pulley	300.387
27	Rivet 3.2x12 mm	P...485B



MS-12 12-Inch Mini Scrub Autoscrubber Suction Nozzle Parts List and Schematic Drawing

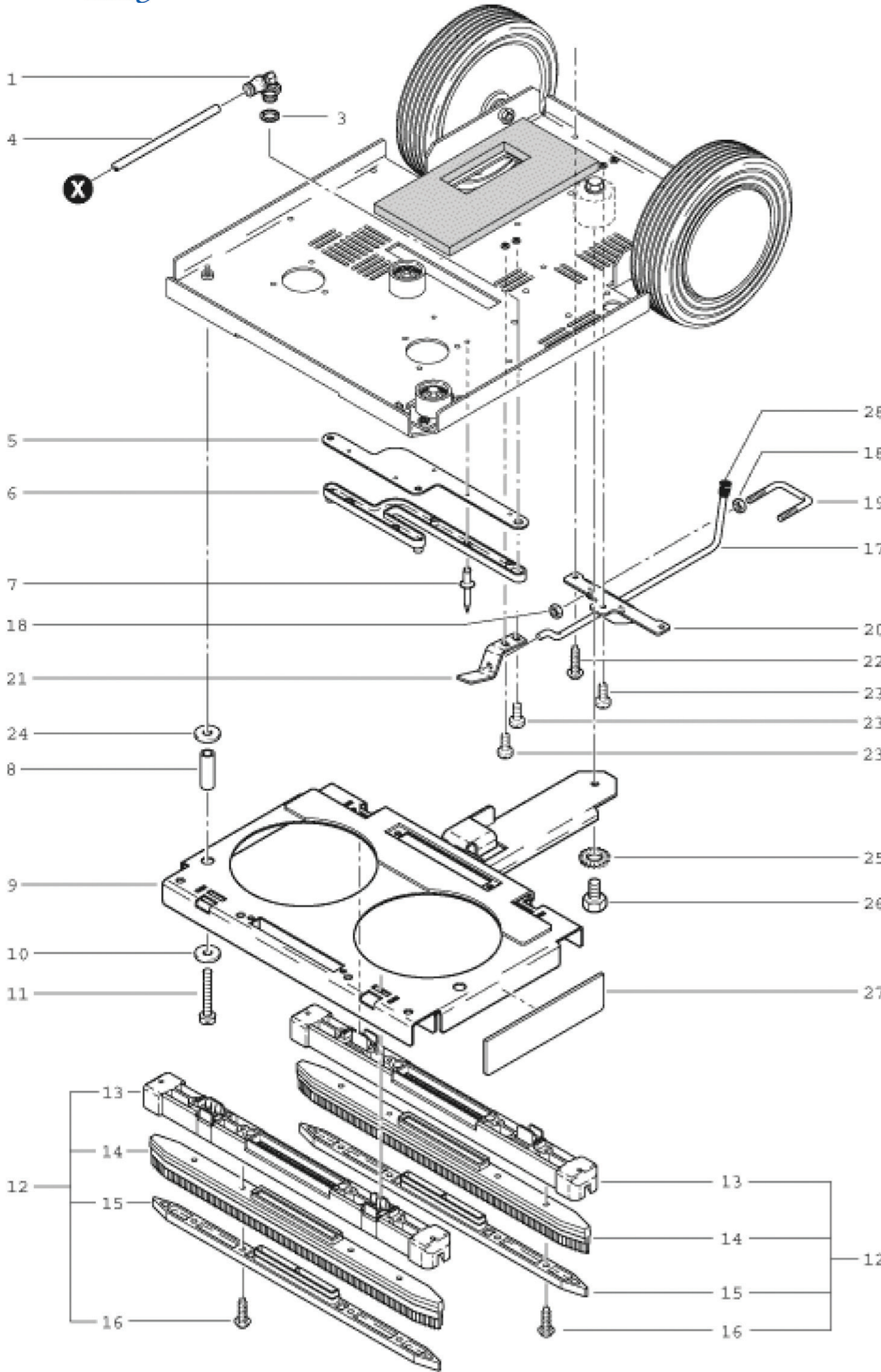

Pos.	Description	Reference
01	Angled connector	P...533H
	Sealing ring	P...533I
04	Connection hose 640mm	300.165
	Water canal isolation	300.081
06	Water canal	300.022
	Rivet 3.2x16.2mm	P...485B
08	Guide sleeve	300.435
	Suction nozzle holder compl.	300.405
10	Washer M6	P...497W
	Screw M6x40	P...477M
12	Suction nozzle complete - including: items 13-16	300.420
	Suction nozzle	300.425
14	Rubber blade	300.422
	Holder for rubber blade	300.428
16	PT-screw KA50x16	P...516H
	Lever	300.416
18	Hexagon nut M6	P...490D
	Protection of lever	300.411
20	Rear guiding holder for lever	300.413
	Front guiding holder for lever	301.415
22	PT-screw KA40x16	P...516C
	Screw M4x8	P...481P
24	Washer M 6	P...496L
	Serrated lock washer M8	P...498G
26	Hexagon screw M8x10	P...471B
	Splash protection	300.312
28	Cap black	P...170K

MS-12 12-Inch Mini Scrub Autoscrubber Brushes Parts List and Schematic Drawing

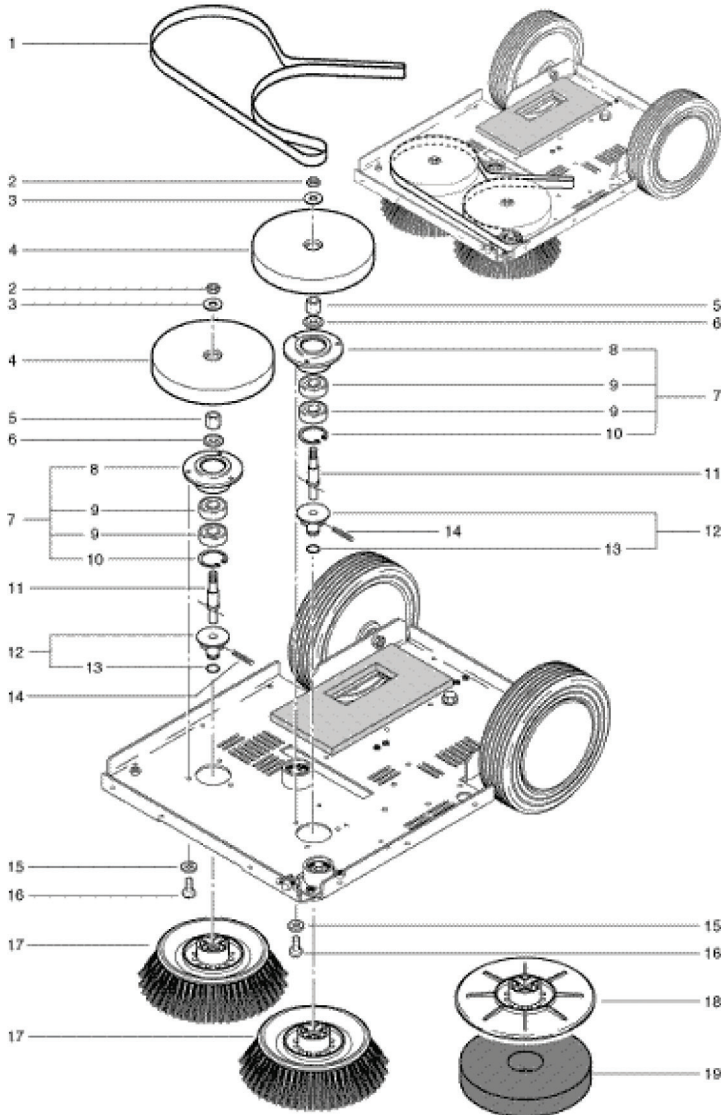

Pos.	Description	Reference
01	Belt	300.121
02	Hexagon nut M8	P...490E
03	Washer M8	P...497T
04	Wheel	300.362
05	Hub S 24x12.8 mm	300.369
06	Washer dm 22 mm	300.352
07	Bearing housing complete - including: items 8-10	300.365
08	Bearing housing complete	300.366
09	Ball bearing	P...316D
10	Retaining ring dm 32 mm	P...514K
11	Axle	300.116
12	Centering pin with o-ring	300.368
13	O-ring 9.19x2.62 mm	P...960U
14	Pin d 4x30 mm	P...512F
15	Washer M4	P...496D
16	Screw M 4x8 mm	P...481P
17	Brush dm 170 mm	300.059
18	Driving disc - dm 16.5 cm (Optional accessories)	300.070
19	Pad red - dm 16.5 cm (Optional accessories)	300.010
19	Pad brown - dm 16.5 cm (Optional accessories)	300.020



MS-12 12-Inch Mini Scrub Autoscrubber Wiring Diagram

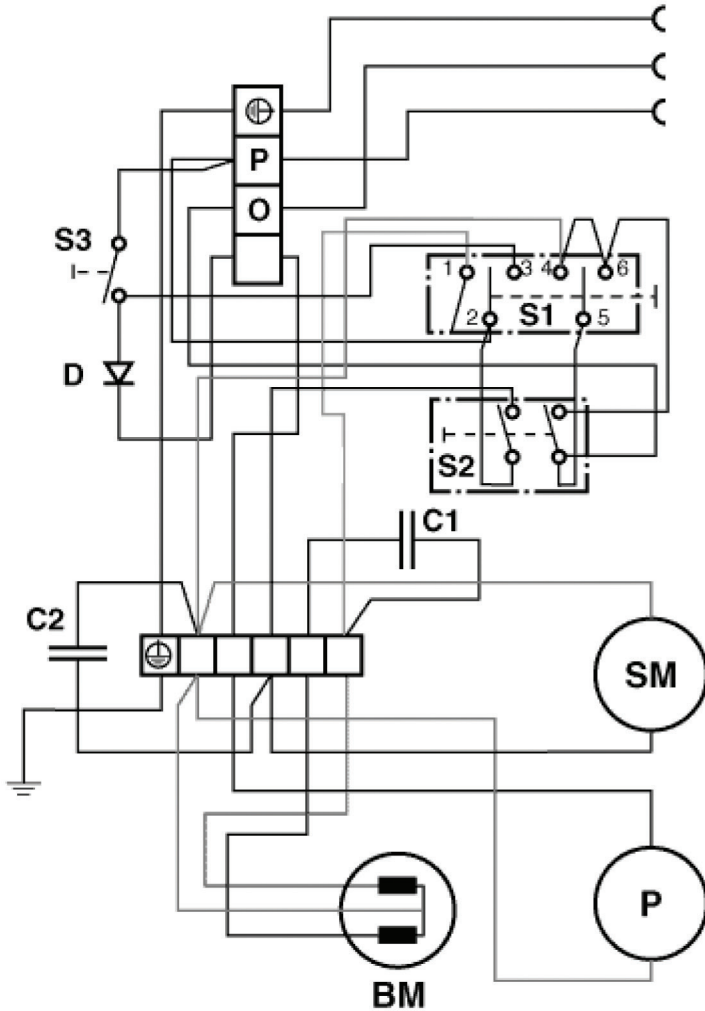

Pos.		Reference
BM	Brush motor	300.281
C1		P...385I
C2	Capacitor	P...387A.
D		
P	Pump NDS-L	P...815
S1		P...240M
S2	Tumbler switch vacuum motor	P...240
S3		950.453
SM	Vacuum motor 800 W	P...870C