

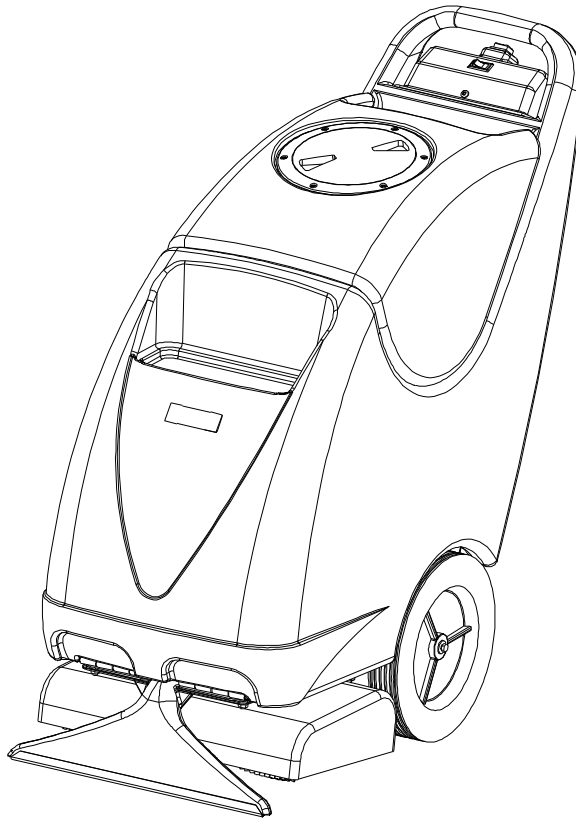

# OWNER'S MANUAL

IMPORTANT: READ OWNER'S MANUAL CAREFULLY



MODEL : \_\_\_\_\_ BOBCAT 10



FOR YOUR CONVENIENCE, RECORD THE FOLLOWING  
IMPORTANT INFORMATION

MODEL: \_\_\_\_\_

SERIAL NUMBER: \_\_\_\_\_

DATE PURCHASED: \_\_\_\_\_

PURCHASED FROM:

# TABLE OF CONTENTS

Machine Components	3
Safety Precautions	4
Machine Set Up	5
Machine Operation	5-6
Machine Maintenance & Storage	6-7
Troubleshooting	8
Parts Lists	9-20
Wiring Diagram	21
Warranty Policy	22

## MACHINE COMPONENTS

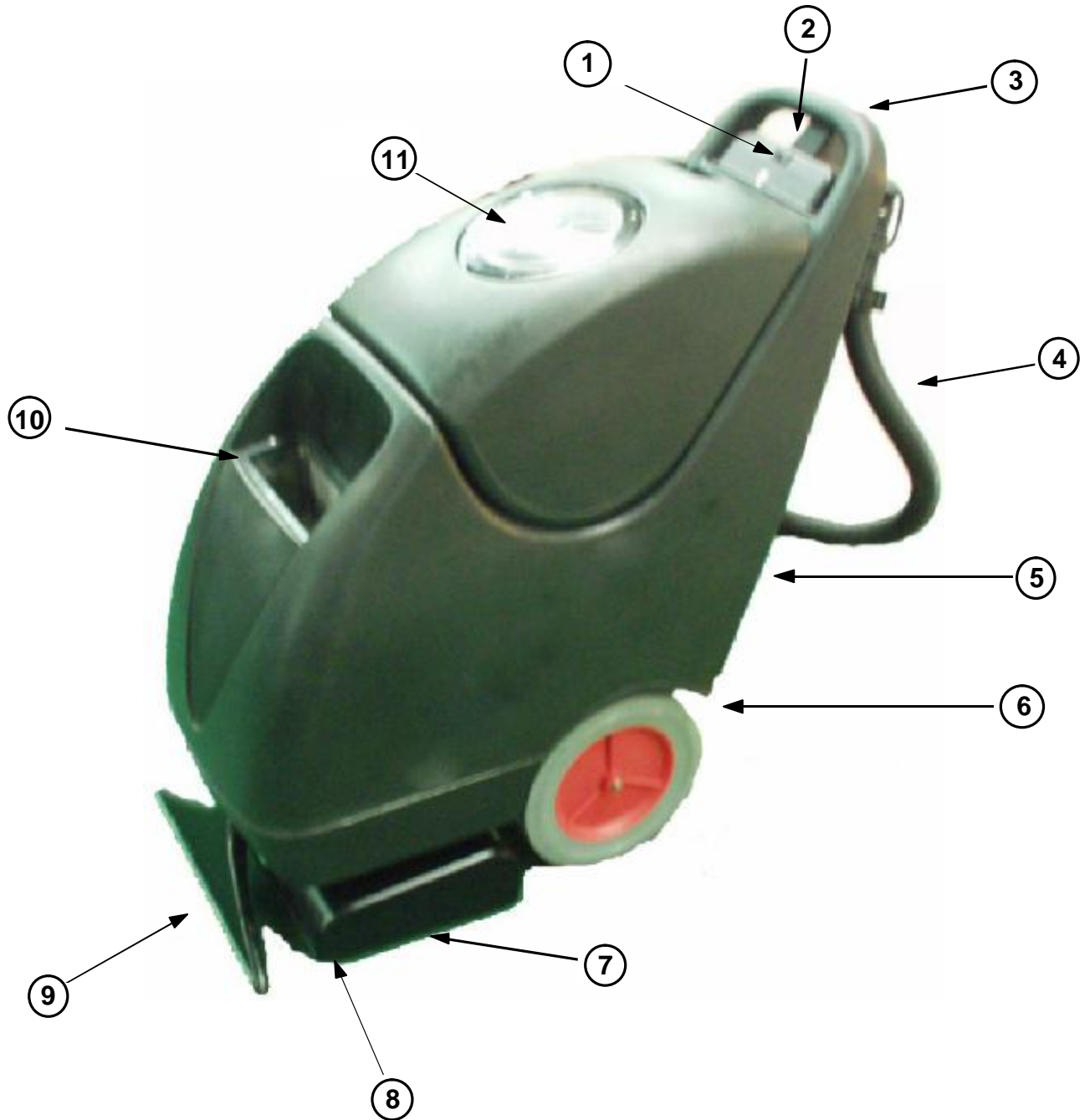

- 1) Vacuum / pump on/off switch
- 2) Brush circuit breaker
- 3) Brush / spray on/off button
- 4) Drain hose
- 5) Accessory tool solution hookup
- 6) Brush raise and lower foot pedal

- 7) Spray jets
- 8) Brush assembly
- 9) Pickup head
- 10) Solution tank fill port
- 11) Recovery tank lid

---

---

## SAFETY PRECAUTIONS

---

---

### GROUNDING INSTRUCTIONS

General – This carped extraction machine shall be grounded while in use to protect the operator from electric shock. The machine is provided with a three-contact grounding type attachment plug to fit the proper grounding type receptacle. The green (or green & yellow) conductor in the cord is the grounding wire. Never connect this wire to other than the grounding pin of the attachment plug.

This machine is for use on a nominal 120-volt circuit and has a grounding plug that resembles the plug illustrated in figure below. Make sure that the machine is connected to an outlet having the same configuration as the plug. No adapter should be used with this machine.

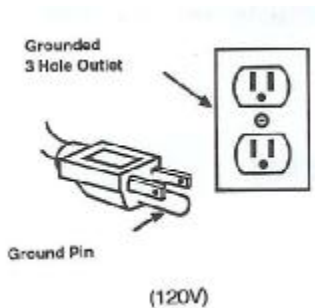

This machine is intended for commercial use. It is constructed for use in an indoor environment and is not intended for any other use. Use only recommended accessories. All operators shall read, understand and exercise the following safety precautions:

**1) Do not operate machine:**

- Unless trained and authorized
- Unless you have read and

- understand operators manual
- In flammable or explosive areas.
- With damaged or modified cord or plug.
- If not in proper operating condition.
- In outdoor areas.
- In standing water.
- Without filters in place.
- With the use of unapproved extension cords.

**2) Before operating machine:**

- Make sure all safety devices are in place and operate properly.

**3) When using machine:**

- Mix and handle any chemicals according to manufacturer's recommendations
- Do not run machine over cord.
- Do not pull machine by cord or plug.
- Do not pull cord around sharp edges or corners.
- Do not unplug by pulling on the cord.
- Do not stretch cord.
- Do not handle plug with wet hands.
- Keep cord away from heated surfaces.
- Do not pick up flammable materials or reactive metals.
- Report machine damage or faulty operation immediately.

**4) Before leaving or servicing machine:**

- Turn off machine.
- Unplug power cord from outlet.

**5) When servicing machine:**

- Unplug cord from outlet.
- Use manufacturer supplied or approved replacement parts.
- Avoid moving parts. Don't wear loose clothing.

---

## SLIDER EXTRACTOR SETUP

---

**!!! Read operators manual thoroughly prior to operating or servicing this machine!!!**

Carefully check the shipping carton for signs of damage. Report any carton damage to carrier immediately.

Check carton contents to ensure carton is complete. Contact your Viper distributor if anything is missing.

Contents:

- Carpet Extractor
- Short “bleeder” vacuum hose
- 50’ extension power cable

**!!! Read operators manual thoroughly prior to operating or servicing this machine!!!**

- 1) Using a hose or bucket, fill tank with a maximum of 10 gallons of hot water.



- 2) Add distributor recommended cleaning solution  
**!!! Do not use flammable liquids or operate machine in or near flammable liquids or vapors!!!**
- 3) Connect the supplied extension power cable to the machine. Plug cord into a grounded wall outlet. (see grounding instructions)
- 4) Drop the brush head to the floor with the foot release pedal on the back of the machine.

---

## MACHINE OPERATION

---

---

### PRIOR TO EXTRACTING CARPETS

---

- 1) Inspect power cable and extension cable for damage. Replace cable if damage is found.
- 2) Vacuum carpet to remove debris prior to extracting carpet.

---

### CARPET EXTRACTING

---

- 1) Turn on vacuum / pump switch.  
*NOTE: Solution will only spray when the brush / spray button is pushed.*
- 2) To start cleaning, push the brush / spray button and begin to pull the machine backwards.



*NOTE: For best cleaning results, pull back on the machine at a pace of approx. 10 feet in 15 seconds.*

- 3) Release brush / spray button at the end of the path, and continue to pull machine back for another 12 inches to pick up excess solution.
- 4) Tip machine back onto the transport wheels and push forward to begin next path.

---

### OPERATING HINTS

---

- 1) Overlap cleaning path by approx. 2 inches
- 2) Work away from power outlet and power cable in order to avoid damage to the power cable.

- 3) Continually check for foam buildup in recovery tank. Use a distributor recommended foam control solution.

*NOTE: Excessive foam buildup will not activate the float shut-off and may cause damage to the vacuum motor.*

- 4) Repeat extraction path on heavily soiled areas.
- 5) If brush stops spinning, there may be an obstruction in the brush. Unplug the power cable, raise the brush off the floor and check for an obstruction. Check & reset the brush circuit breaker located on the control housing.
- 6) When recover of the dirty solution ends, or the solution tank is empty, you must drain the recovery tank. (see TANK DRAINING)

---

#### USE OF ACCESSORY TOOLS

---

*NOTE: Prior to cleaning upholstery, be sure to read cleaning instructions provided by the manufacturer.*

- 1) Disconnect black vacuum hose off the back right side of the machine. Connect (optional) accessory vacuum hose to area where the standard vacuum hose was removed.
- 2) Connect (optional) accessory solution hose to brass quick connect coupler located on the back of the machine.
- 3) Connect (optional) accessory tool to solution and vacuum hoses.
- 4) Turn on vacuum / pump switch.
- 5) Operate accessory tools as needed.
- 6) When cleaning is completed, relieve water pressure from solution lines by turning off vacuum / pump switch and then squeeze trigger for 4 seconds.

---

## DRAINING TANKS

---

---

### DRAINING SOLUTION TANK

---

- 1) Disconnect vacuum hose from back of machine and connect the “bleeder” vacuum hose (included with machine) to the machine back.
- 2) Remove the solution tank filter at the fill area and place end of “bleeder” hose into the bottom of the tank.
- 3) Turn on vacuum / pump switch & vacuum out the remaining solution.

---

### DRAINING RECOVERY TANK

---

- 1) Turn off machine, unplug and remove power cable.
- 2) Unhook drain hose off the back of the machine and remove drain hose stopper.
- 3) Drain dirty solution into floor drain.



- 4) Replace drain hose stopper and reattach hose to back of machine.

---

## MACHINE MAINTENANCE

---

To keep the machine performing well for many years, please follow the following maintenance procedures.

**!!! Always confirm that the machine is unplugged prior to performing any maintenance or repairs!!!**

---

### DAILY MAINTENANCE

---

- 1) When cleaning operation is complete for the day, drain and rinse the recovery tank thoroughly with clean water.
- 2) Remove remaining solution from solution tank.
- 3) Remove float shut-off (ping pong ball in cage) from recovery tank and clean with water.



- 4) Remove and inspect brass spray jets. If necessary, clean jets in acetic acid solution.

*NOTE: Do not clean brass jets with a pointed object, as it will damage the jets.*

- 5) Check brush assembly & remove any debris or carpet fibers.
- 6) Check pick up head and remove any debris or carpet fibers.
- 7) Check condition of the stainless steel pickup shoes on the pickup head. The shoes must contact the floor for the whole length of the pickup head. Replace as necessary.
- 8) Clean machine with a nonabrasive cleaner.
- 9) Inspect power cable for any damage. Replace if necessary.

---

### MONTHLY MAINTENANCE

---

- 1) Flush pump & plumbing with an acetic acid solution to dissolve any chemical buildup.

### Mixing Instructions:

- a) Premix 16 oz. of an acetic acid solution with 2 gallons of water and pour into solution tank.
  - b) Turn vacuum / pump switch on
  - c) Put machine head over floor drain and operate machine for 50 seconds.
  - d) Shut machine down and allow remaining solution to sit in machine overnight.
  - e) The following day, spray out remaining solution and flush system again with 3 gallons of clean water.
- 2) Inspect machine for water leaks.
  - 3) Lubricate wheels with a water resistance lubricant.
  - 4) Check machine for loose or missing nuts, screw and bolts and replace as necessary.

---

### MACHINE STORAGE

---

- 1) Prior to storing the machine, ensure the solution and recovery tanks are clean and empty of any solution.
- 2) Store machine in upright position in a dry area, with the brush head off the floor.
- 3) Remove recovery tank clear lid to allow for air circulation.

*NOTE: If you are storing the machine in an area which can freeze, be sure both tanks and the solution plumbing are empty of all water and dry!*



## **BASIC TROUBLESHOOTING**

PROBLEM	CAUSE	SOLUTION
Machine doesn't work	Not plugged in to power source	Plug into a grounded outlet
	Faulty power cable	Contact Distributor
	Faulty extension power cable	Replace with new extension power cable
	Building circuit breaker tripped	Reset circuit breaker
Solution pump not working	Vacuum / pump switch not on	Turn on switch
	Vacuum / pump switch faulty	Contact Distributor
	Faulty solenoid	Contact Distributor
	Faulty solution pump	Contact Distributor
	Pump overheated	Determine cause and allow 30 minutes for pump to cool
	Loose or broken wiring	Contact Distributor
Vacuum motor not working	Vacuum / pump switch not on	Turn on switch
	Vacuum / pump switch faulty	Contact Distributor
	Vacuum motor thermal overload tripped	Check for obstruction and allow 30 minutes to cool
	Faulty vacuum motor	Contact Distributor
	Worn carbon brushes	Contact Distributor
	Loose or broken wiring	Contact Distributor
Poor pick up	Air leaking around clear recovery lid	Ensure recovery lid is firmly tightened
	Clogged float shut-off	Remove float shut-off and clean off debris
	Float shut-off is activated	Drain recovery tank
	Loose drain hose stopper	Ensure stopper is securely in place
	Loose vacuum hose connections	Ensure vacuum hose connections are tight
	Defective vacuum hose	Replace vacuum hose
	Loose vacuum hose cuffs	Ensure cuffs are secure to the hose
	Damaged or loose pickup head shoes	Contact Distributor
	Pulling machine too fast	Slow down cleaning operation
Uneven or no solution spray	Solution tank is empty or low	Fill solution tank
	Vacuum / pump switch not on	Turn on switch
	Dirty or plugged spray tips	Clean or replace spray tips
	Improper spray tip size or spray angle	Contact Distributor
	Worn spray tips	Contact Distributor
	Faulty solution pump	Contact Distributor
	Plugged solution tank filter	Clean or replace filter
	Pinched or kinked solution hose	Check for obstructions and kinks and reroute or replace if needed



# Solution and Recovery Tank Assembly

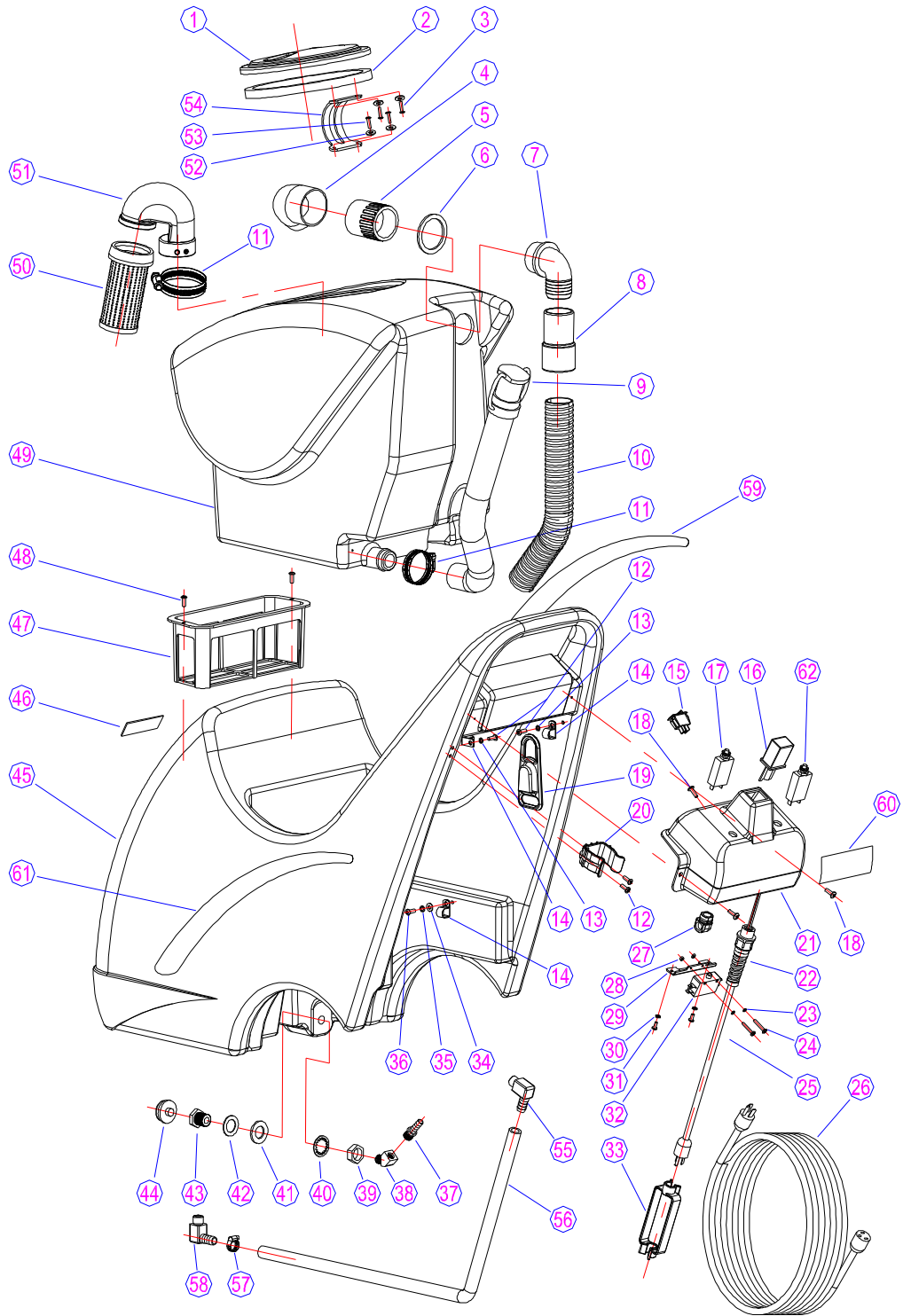

## Solution and Recovery Tank Assembly Parts List

DIA NO	PART NUMBER	DESCRIPTION	NO REQ'D
1	VV67161	CLEAR DOME, FRICTION FIT	1
2	VV67163	GASKET, CLEAR DOME	1
3	VV96002	SEAT, SCREW IN LID	1
4	VV67109	BEND, TUBE	2
5	VV67301	COUPLER	2
6	VV67302	GASKET, COUPLER	1
7	VV67108	ELBOW	1
8	VF81226	COUPLER VAC HOSE	1
9	VV67705	DRAIN HOSE	1
10	VV67113-1	VAC HOSE	1
11	VV10113	CLAMP, HOSE 2"	2
12	VV20509	SCREW, RHM M5X10 SST	4
13	VV13601	WASHER, LOCK, SST Ø5	2
14	VV50712	CLAMP, CORD	3
15	VV67503	SWITCH	1
16	VV67509	BUTTON, SWITCH	1
17	VV67504	CIRCUIT BREAKER, 2A	1
18	VF14126	SCREW, M5X12, HEX	3
19	GV40215	CORD WRAP	1
20	VV67111	CLAMP, DRAIN HOSE	1
21	VV67501	SWITCH HOUSING	1
22	VF99008	STRAIN RELIEF	1
23	VV13511	WASHER, TEETH, $\phi$ 3	2
24	VF14212	SCREW, M3X25	2
25	VV67507TR	CORD	1
26	VV67116TR	POWER CORD	2
27	VV67505	BUSHING, CORD, 90°	1
28	VV13652	NUT, LOCK, M3	2
29	VV67508	BRACKET, SWITCH	1
30	VV20291	WASHER, LOCK, $\phi$ 4	2
31	VF13491	SCREW, M4X12	2
32	VF44203	SWITCH ASSY	1
33	VV67105	CONNECTOR	1
34	GT13032	WASHER, PLAIN, Ø6XØ16X1.5	1
35	VV13607	WASHER, LOCK, SST Ø6	1
36	GT13056	SCREW, M6X16, PH	1
37	VV80128	BARB, HOSE	1
38	VV80115	ELBOW, STRECT 45°	1
39	VV80125A	NUT, COUPLING	1
40	VV20667	WASHER, LOCK, INTERNAL TOOTH	1
41	VV60509	GASKET, SOLUTION, INTAKE	1
42	VV20276	WASHER, PLAIN	1

## Solution and Recovery Tank Assembly Parts List

DIA NO	PART NUMBER	DESCRIPTION	NO REQ'D
43	VV80125	COUPLING	1
44	VV10411	STRAINER, LINE	1
45	VV67101	SOLUTION TANK	1
46	VF47035TR	LOGO	1
47	VV67107	FILTER	1
48	VA13471	SCREW, ST5X10	2
49	VV67102	RECOVERY TANK	1
50	VF81504	FLOAT, SHUT-OFF	1
51	VV67305	BEND	1
52	VV13664	WASHER, PLAIN, $\phi 4\phi 12X1$	4
53	VF13491	SCREW, M4X12, SST	2
54	VV67162	RUBBER HINGE	1
55	VF81403A	ELBOW, 90°, BRASS	1
56	VV67708	TUBING	1
57	VF82090	CLAMP(16-20)	1
58	VV67711	ELBOW, 90°, BRASS	1
59	VV67118TR	LABEL, RIGHT	1
60	VF80331	DECAL, WARNING	1
61	VV67119TR	LABEL, LEFT	1
62	VF99010C	CIRCUIT BREAKER, 17A	1
63	VA20104A	PLUG, DRAIN HOSE	1
64	VA13477	SELF-TAPPING SCREW, ST4X16	2

# Vac, Pump, Wheels & Brush Housing Assembly

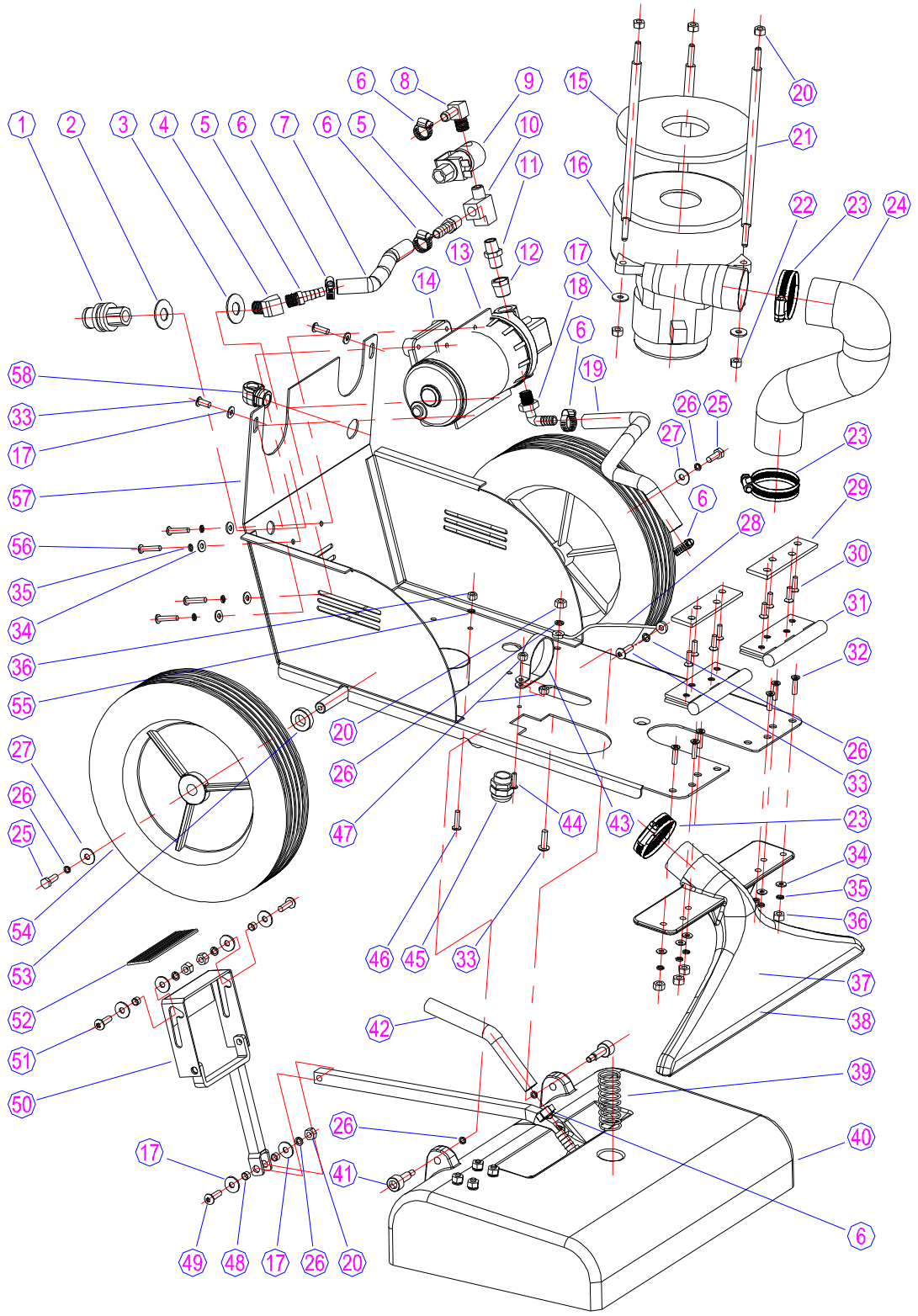

## Vac, Pump, Wheels & Brush Housing Assembly Parts List

DIA NO	PART NUMBER	DESCRIPTION	NO REQ'D
1	RD80208	COUPLER,QUICK CONNECT	1
2	VV20274	WASHER,PLAIN,Ø13.5XØ32X1.5	1
3	VV20274A	WASHER,PLAIN,Ø14XØ32X1.5	1
4	VV80115	ELBOW,STRECT,45°	1
5	VV80128	BARB,HOSE	2
6	VV10114	CLAMP,HOSE,3/8"	6
7	VV67114	HOSE,HIGH PRESSURE	1
8	VV67607	BARB,PUMP	1
9	VV67604	SOLUTION SOLENOID,110V/60HZ	1
10	VV67606	CONNECTOR,THREE-WAY	1
11	VV67603	CONNECTOR	1
12	VV67602	BARB,PUMP	1
13	VV67601	MOUNTING FRAME,PUMP	1
14	VV67605	PUMP,115V,100PSI	1
15	VF81503	GASKET,VAC MOTOR	1
16	VV67154	VAC MOTOR,3-STAGE,120V	1
17	GT13032	WASHER,SST,PLAIN,Ø6XØ16X1.5	11
18	VV80210	BEND,NYLON,PUMP	1
19	VV67117	HOSE,SOLUTION	1
20	VF13521	NUT,SST,M6	6
21	VF81508	STUD	3
22	VF14506	NUT,LOCK,SS,M6	3
23	VV10113	CLAMP,HOSE 2"	3
24	VV67152	EXHAUST HOSE,Ø48	1
25	VF13495	BOLT,M6X16,HEX	2
26	VV13607	WASHER,LOCK,Ø6	11
27	VF13551	WASHER,SST,PLAIN,Ø6XØ22X1.5	2
28	VF82028	CABLE	1
29	VV67104	SPACER	2
30	VF13512	SCREW,FH,M5X15,SST	8
31	VV60406S	HINGE,SST,4"	2
32	GT13058	SCREW,FH,SST,M5X22	6
33	GT13056	SCREW,SST,PH,M6X16	4
34	VF13474A	WASHER,SST,PLAIN,Ø5XØ15X1	10
35	VV13601	WASHER,LOCK,Ø5	10
36	VV13633	NUT,SST,M5	7
37	VV67140	CARPET PICK-UP TOOL	1
38	VV67142	STAINLESS STEEL SHOES	2
39	VV67407	SPRING	1
40	VV67400	MOUNTING BASE ASSY,BRUSH	1
41	VV67110	SHOULDER SCREW	2
42	VV67115	HOSE,SPRAYING	1

## Vac, Pump, Wheels & Brush Housing Assembly Parts List

DIA NO	PART NUMBER	DESCRIPTION	NO REQ'D
43	VV67120	CLAMP	1
44	VA13473	SCREW,RHM,M4X16,SST	1
45	VV67405	STRAINER	1
46	VV13635	SCREW,RHM,M5X20,SST	1
47	GT13014	NUT,NYLON,INSERT,M4	2
48	VV67106	SPACER	4
49	VA13478	SCREW,M6X35,HEX	1
50	VV67103A	FOOT STEP	1
51	VF14127	SCREW,RHM,M6X20,SST	2
52	VV67121	ANTISKID PLATE	1
53	VV60113S	WASHER,WHEEL,AL	2
54	VA75004TR	WHEEL,10"	2
55	VF13604	WASHER,Ø5	1
56	VV13634	SCREW,RHM,M5X30,SST	4
57	VV67200	BOTTOM PLATE,ASSY	1
58	VV67505	BUSHING,90°,CORD	1
59	VF143001	SCREW,PH,M3X4,SST	4

# Brush Housing Assembly

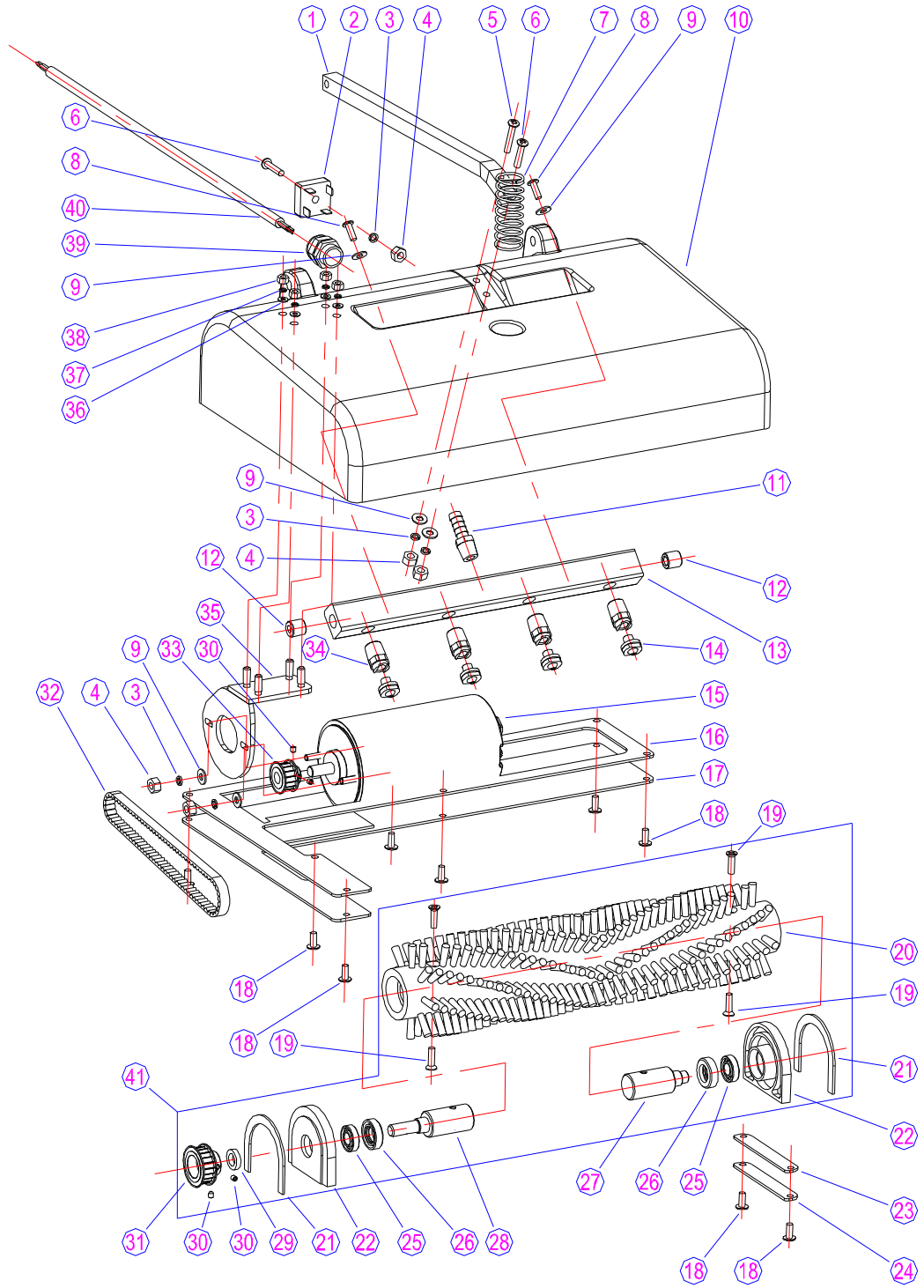

## Brush Housing Assembly Parts List

DIA NO	PART NUMBER	DESCRIPTION	NO REQ'D
1	VV67403-2A	LIFT BAR	1
2	VV99926-1	RECTIFIER	1
3	VV13601	WASHER,LOCK,SST,Ø5	5
4	VV13633	NUT,SST,M5	5
5	VV13634	SCREW,SST,PH,M5X30	1
6	VA13475	SCREW,PH,SST,M5X25	2
7	VV67407	SPRING	1
8	VV20501	SCREW,PH,SST,M5X14	2
9	VV13662	WASHER,PLAIN,Ø5XØ12X1	6
10	VV67401	MOUNTING BASE,BRUSH	1
11	VV80128	BARB,HOSE	1
12	VV67423	INSERT,SPRAYER BODY	2
13	VV67421	SPRAYER BODY	1
14	VV67422	SPRAY TIP	4
15	VV67435	MOTOR,110V	1
16	VV67433	GASKET	1
17	VV67431-1	BOTTOM PLATE	1
18	GT13054	SCREW,BH,M5X12,SST	10
19	VF13512A	SCREW,FH,SST,M5X18	4
20	VV67412	BRUSH	1
21	VV67417	GASKET	2
22	VV67414	FRAME,BRUSH	2
23	VV67404	PLATE	1
24	VV67406	GASKET	1
25	VF14024	BEARING	2
26	VF14023	SEAL	2
27	VV67411	SHAFT,BRUSH	1
28	VV67413	AXLE,PULLEY	1
29	VV67416	SPACER	1
30	GT13059	SCREW,HEX,SOCKET	4
31	VV67415	DRIVEN PULLEY	1
32	VV67402	BELT	1
33	VV67432	DRIVING PULLEY	1
34	VV67424	NOZZLE BODY	4
35	VV67436	MOUNTING BRACKET, MOTOR	1
36	GT13032	WASHER,SST,PLAIN,Ø6XØ16X1.5	4
37	VV13607	WASHER,LOCK,Ø6	4
38	VF13521	NUT,SST,M6	4
39	VV67405	STRAIN RELIEF	1
40	VV67408	POWER CORD	1
41	VV67410	BRUSH ASSEMBLY	1



# Upholstery Tool Assembly

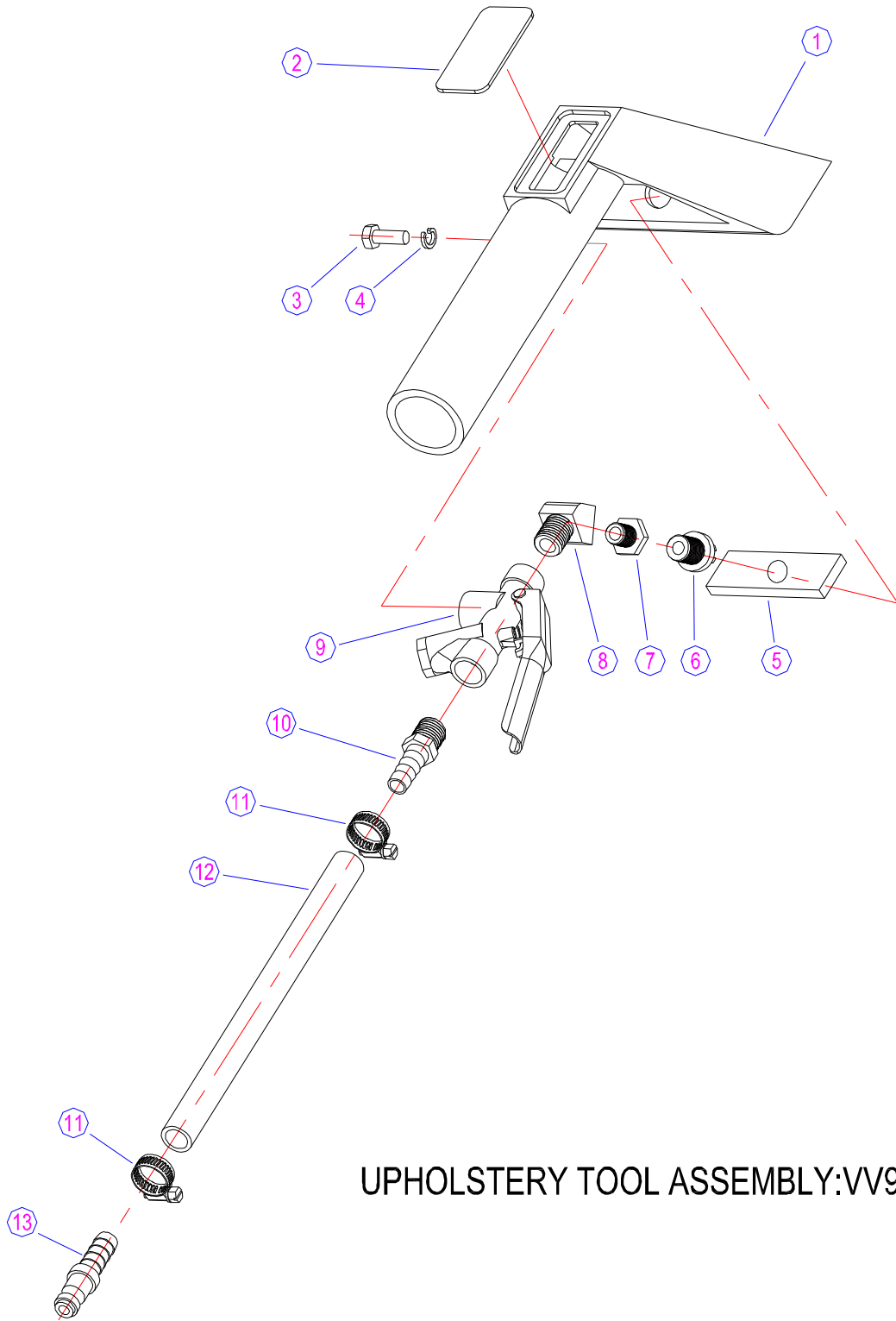

UPHOLSTERY TOOL ASSEMBLY:VV91559

## Upholstery Tool Assembly Parts List

DIA NO	PART NUMBER	DESCRIPTION	NO REQ'D
1	VV40328	UPHOLSTERY TOOL	1
2	VV40328-6	WINDOW,HAND TOOL	1
3	VV20071	SCREW,5/16-18X5/8"L,HH	1
4	VV20298	WASHER, LOCK, 5/16"L, SST	1
5	VV60531	GASKET	1
6	VV80159	NOZZLE, SPRAY TIP, 80°	1
7	VV80105	BUSHING, BRASS	1
8	VV80115	ELBOW, STREET, 45 DEGREES	1
9	VV10933	TRIGGER VALVE	1
10	VV80128	BARB, HOSE	1
11	VV10114	CLAMP, HOSE 3/8"	2
12	VV85317	SOLUTION HOSE, 3/8"	1
13	VV80241	BARB, HOSE MAIL PLUG	1

# Hose Assembly

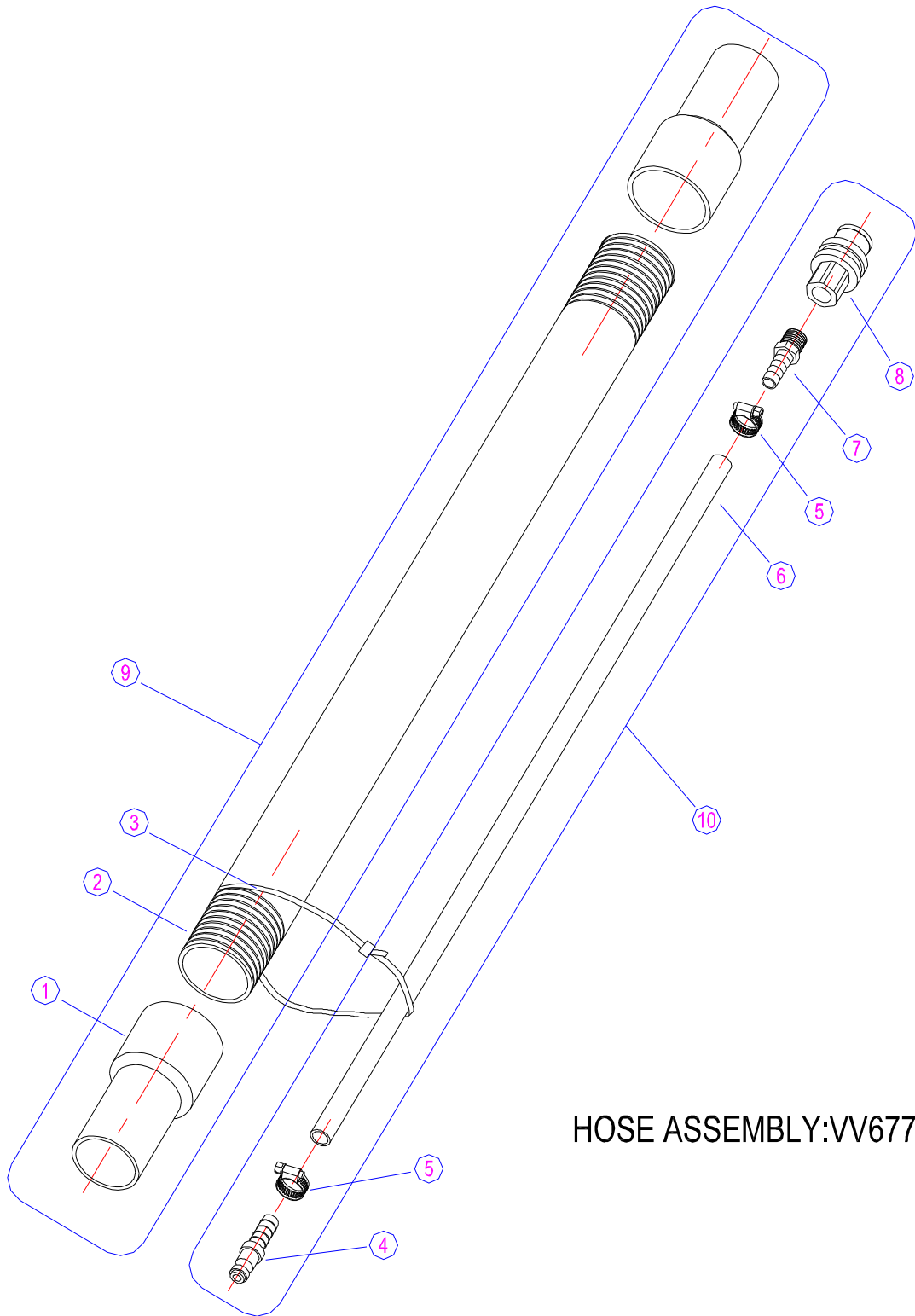

HOSE ASSEMBLY:VV67702

## Hose Assembly Parts List

<b>DIA NO</b>	<b>PART NUMBER</b>	<b>DESCRIPTION</b>	<b>NO REQ'D</b>
1	VV60220	CUFF, 1 1/2"	2
2	VV67703	HOSE, VACUUM	1
3	VV20652	TIE, CABLE	16
4	VV80241	HOSE BARB,MAIL PLUG, SST	1
5	VV10114	CLAMP, HOSE, 3/8",SST	2
6	VV67704	HOSE, SOLUTION, 16'LONG	1
7	VV80128	HOSE BARB	1
8	RD80208	COUPLER, QUICK CONNECT	1
9	VV67703A	VACUUM HOSE ASSEMBLY	1
10	VV67704A	SOLUTION HOSE ASSEMBLY	1

# Wiring Diagram

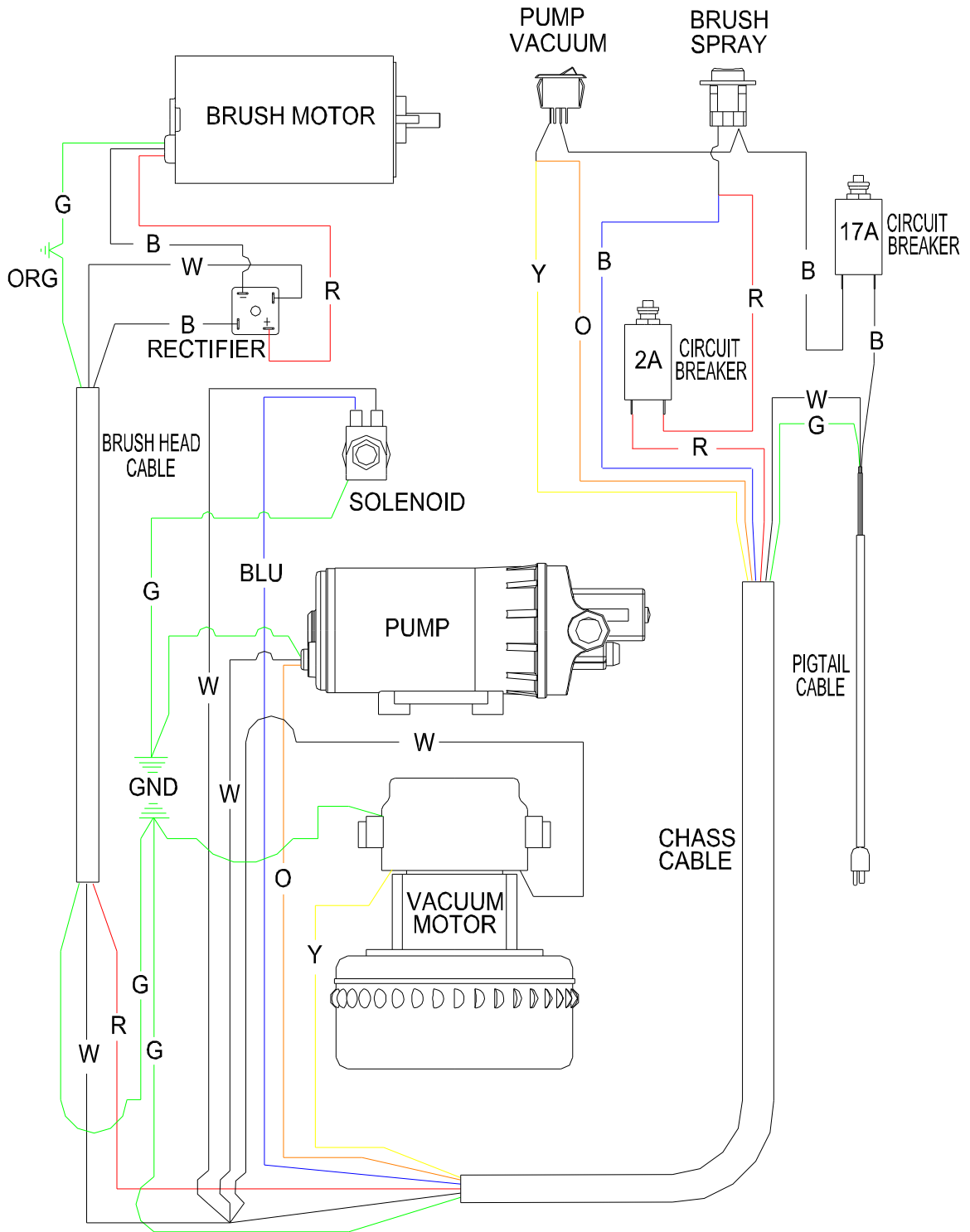



## WARRANTY POLICY

The warranty terms outlined below are in lieu of any other warranties, either stated or implied, including any implied warranty of merchantability, fitness for a particular purpose or otherwise. Under no circumstances will seller be liable for any loss, damage, expense or consequential damages arising in connection with the use or inability to use this product.

This warranty does not apply to damage or defect caused by accident, misuse, negligence, abuse, fire or to any Triple S product which has been serviced by anyone other than a Triple S authorized service representative. Housings or parts that have become damaged as a result of improper use of the machine are excluded from this warranty. Refer to owner's manual for proper machine use and maintenance. Parts that are expected to wear from normal use and, therefore are not covered under the parts warranty include, but are not limited to: batteries (pro-rated for one year); bearings; belts; brushes; filters; squeegees; switches; and tires.

This warranty commences on the date of purchase of the product by the original end user from an authorized Triple S distributor, subject to proof of purchase. If proof of purchase date is unavailable, the warranty begins 90 days after the sale of the product to an authorized Triple S distributor.

- Subject to the conditions outlined above, the manufacturer warrants the rotationally-molded polyethylene housings and parts on its machines to be free from defects in materials and workmanship, under normal use and service for twelve (12) years to the original purchaser.
- Under this warranty, the manufacturer guarantees the performance of non-polyethylene parts and components on Triple S machines to be free from defects for up to five (5) years to the original end user. Parts replaced under this warranty are guaranteed for the remainder of the original warranty period.
- Labor charges are covered for two (2) full years from the date of purchase for Triple S products, provided an authorized Triple S service provider is used for repair. No travel coverage is extended for cord electric machines.

Product Exceptions & Exclusions: Battery chargers and all accessories are warranted for one year.

*Triple S reserves the right to change the warranty policy without notice.*